

JA-60GSM dialer module

Installation manual

The JA-60GSM dialer is constructed for JA-60, 63 and 65 alarm control panels. The dialer is used for communication via GSM. Appropriate GSM provider is chosen by inserted SIM card. This Installation manual is intended for JA-60GSM version FJ61403.

The GSM module, when installed in the alarm control panel, enables:

- Automatic sending of an event's text messages to up to 8 mobile phones
- Dialing of programmed telephone numbers and playing of an audible warning signal
- Data transfer to one or two Central Monitoring Stations (CMS)
- Remote control and programming of the alarm system via SMS instruction messages from a mobile phone or from Jablotron's SMS website
- Remote control and programming of the alarm system using a telephone set keypad (mobile or land line)
- Remote control of an appliance (heating system etc.) via telephone (mobile or land line)
- Phone calls using a telephone set attached to the dialer module (via the GSM network)
- The "Piccolo" SMS terminal can be used for easy and convenient receiving and sending of SMS messages
- Internet connection using the GPRS data transfer
- Programming of the alarm system via ComLink software
- Programming and remote supervision of the alarm system via Jablotron's website gsmlink.jablotron.cz

1 Installation of the dialer

The JA-60GSM dialer can be installed into the telephone communicator's position in a JA-60, 63 or 65 control panel (either a GSM module or a telephone line communicator module can be used in a control panel – it is not possible to install both simultaneously).

- Disconnect** the control panel's **power** supply (both AC and backup battery). If the control panel has been previously used before this installation, enter the programming mode before disconnecting the power supply.
- We recommend you to **disable the SIM card PIN code protection** before you insert it into the dialer. Use a mobile phone to perform this task (if you have a NOKIA phone, select: Menu, Settings, Security settings, PIN code request, Off). If you insist on usage of the PIN, see section 5.1.
- Open the SIM card holder** (by sliding it in the direction shown in figure 1) and **insert the SIM card** into the holder **and close it** by sliding it back. – see figure 1.
- Attach the dialer into the control panel case and connect its flat cable to the control panel's main board.
- Connect the **GSM antenna** (never switch the power supply on without a proper antenna)
- Connect a **telephone set** to the PHONE connector (or to PHONE terminals) together with the SMS terminal if desired. Only one telephone set can be attached to the dialer. The PHONE output of the dialer should never be connected to any other telephone network.
- If you use the **AUX output** to control an appliance, connect its cable to the AUX output terminals (normally open dry contact, max. 100mA / 60V) – see figure 1.

- Reconnect the control panel's power supply** (backup battery and AC). The system will show a **P**, (programming mode). The red LED on the GSM dialer will light permanently (indicating that the module is establishing a connection to the GSM network). The **LED will switch off after the connection is successfully established**.

If the LED starts flashing, the module was not able to enter the GSM network. In this case, switch off completely the control panel's power. Remove the SIM card and insert it into a mobile phone to confirm whether it is possible to enter the network in this location. You can also select a desired network manually if options are available. Ensure that the SIM card does not request a PIN code (optional use with PIN code is described in section 5.1). Once the SIM card works in the mobile phone, replace it to the GSM dialer and repeat step h). If the GSM signal is weak in this area, change location of the GSM antenna before you try to reestablish the connection.

- Attach the control panel's cover after the module has entered the GSM network (LED switched off).
- Enter 971** on the alarm system keypad (while in programming mode) to **monitor the GSM signal**. The keypad will show a number from 0 to 9 and it will sound a beep every second indicating a new measurement. For proper functioning of the dialer the signal strength should be 3 or higher. Find the best location for the antenna while measuring the signal strength. To switch the system **back to the programming mode** press the **N** key.
- Without additional programming you can **test the user features** of the dialer (phone calls from an attached phone, remote control of the system via a remote phone, remote control of an appliance etc.). See the following description.
- Set telephone numbers** for the automatic event's reporting and the other selectable features – see part 3.
- Programming of the GSM dialer** is possible by entering programming sequences via the alarm system's keypad (while in programming mode). The most convenient programming method, however is via a connected PC using the Comlink software, or by using the www.GSMlink.cz website.

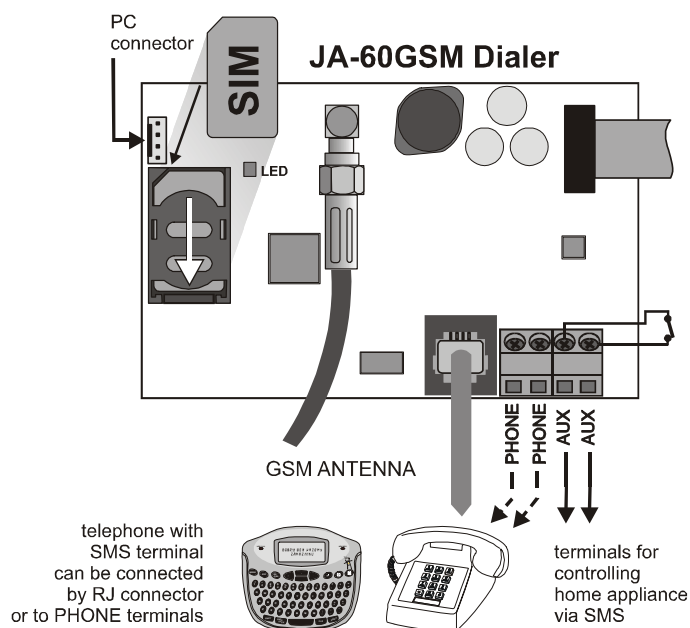

figure 1

2 User features of the GSM dialer

The installed GSM dialer offers many useful features described in detail below, or briefly in table 11. A synopsis is available on the user card. The installer should properly demonstrate the use of the system to the user after installation.

2.1 Phone calls from the attached telephone set

After the GSM module is connected to the GSM network, an attached phone can be used to make calls. If you pick up the phone, you will hear a dial tone. Simply dial the number you want to call (as if you are dialing from a normal fixed line phone). You can also dial the GSM communicator's phone number from another phone, and its attached phone will ring as a normal land line phone would. If it is necessary to communicate with CMS the call from the attached phone will be terminated in 10 minutes.

If there is a busy tone in the attached telephone set, either the line you are calling is busy, or the GSM communicator is busy with a previous communication at that moment (for example data transfer to the monitoring station).

You can also use the attached phone keypad to operate the alarm system. By pressing the # key, you can toggle the keypad from the telephone mode to the alarm system control mode.

Note: some telephone sets are sensitive to the GSM radio signal. For this reason you may hear a characteristic noise in the telephone receiver when calling. If the noise is disturbing, change the location of the phone set (try to keep it as far as possible from the GSM dialer antenna). Usually it is possible to find a suitable location for the phone with a minimal level of interference.

2.2 Telephone remote control of the alarm system

A system equipped with the GSM dialer can be remotely controlled. From a mobile phone there are two possibilities – either by text instructions sent by SMS or by dialing-in and operating the system via the phone keypad which will operate in the same way as the alarm system keypad. The dialing-in method can also be done from an ordinary landline telephone set.

The following description matches the factory default settings of the communicator. The described features can be vastly modified in the programming mode – see part 4.

2.3 General rules for the remote control by SMS instructions

- The SMS instructions can be sent from a mobile phone or from an SMS website.
- In SMS capital letters are not distinguished. Only the basic English alphabet is accepted by the communicator.
- **All SMS instruction words must be separated by a space.**
- # symbol inside the SMS text ends processing – all following text will be ignored. It is recommended to use this symbol at the end of the instruction if the provider is sending some additional text after your message (advertisements etc.).
- The default command texts can be customized by an installer (see 4.2.2). For example the instruction AUXON can be changed to SWITCH ON HEATING etc.

2.4 Arming by SMS (AM xxxx)

The command **AM** followed with a valid access code can be used to arm the alarm system. If the system is already armed, the command will not change this.

Send SMS text to the dialer: **AM*xxxx**

xxxx is a valid alarm system access code (Master or user).
* separating character, which can be replaced by a space

Example: Sending of **AM 1234** will arm the system in the same way as if the code 1234 is used for arming

Notes:

- According to the default setting, the system confirms the command performance with a corresponding SMS reply
- If it is impossible to arm the system – for example it is in the programming mode, you will be notified about the situation by an SMS reply
- If the alarm system is split, the instruction will effect the section which belongs to the used access code *
- If arming without a code is enabled on the control panel, the AM command can be used without any access code. In this case the command performs the same action as the keys F 1 pushed on a keypad.

2.5 Disarming by SMS (DM xxxx)

Command **DM** followed with a valid access code will disarm the system. If the system is already disarmed, the command will not change this.

Send SMS text to the communicator: **DM xxxx**

xxxx is a valid alarm system access code (Master or user).
* separating character, which can be replaced by a space

Example: Sending of **DM*1234** will disarm the system in the same way as if the code 1234 is entered for disarming on a system keypad.

Notes:

- The system confirms disarming with a corresponding SMS reply
 - If it is impossible to disarm the system – for example it is in the programming mode, you will be notified about the situation by an SMS reply
 - If the alarm system is split, the instruction will effect the section which belongs to the used access code *
- * If the alarm system is split and the command is used (AM or DM), the user code will effect the system the same way as if the code is entered from the alarm system keypad – no matter if AM or DM used (will arm if the system is disarmed and will disarm if the system is armed).

2.6 Mode request by SMS (MO)

Command **MO** can be used to read the current alarm system mode. The dialer will reply with a status reporting SMS to the phone which sent the MO command.

Send SMS text to the dialer: **MO**

Example: If the system is armed, it will reply to the **MO** instruction with SMS: Alarm system reports: Control panel status: Armed

Note: if you want to protect this command with a password, set your own instruction text including the password – see section 4.2.2

2.7 Last event request by SMS (ME)

Instruction **ME** can be used to read the last event recorded in the alarm system's memory. The dialer will reply with a reporting SMS.

Send SMS text to the dialer: **ME**

Example: After a fire alarm, it will reply to the **ME** instruction with SMS: Alarm system reports: Last event: Alarm end Control panel Time: 02.06.19:48

Note: if you want to protect this command with a password, set your own instruction text including the password – see section 4.2.2.

2.8 Appliance remote control by SMS (AUXON, AUXOFF)

These commands can be used to operate the AUX output (for example heating in the house). The dialer confirms command performance with an SMS reply.

To switch on the AUX output, send SMS text: **AUXON**
To switch off the AUX output, send SMS text: **AUXOFF**

Example: to switch on heating send SMS: AUXON

Note: texts of these instructions can be customized and protected with a password – see section 4.2.2. Outputs PgX and PgY can be controlled by SMS commands **PGON** and **PGOFF**.

2.9 Remote programming of the alarm by SMS (yyyyy PRG seq)

Command **PRG** can be used to send programming and operating sequences to the alarm system. It has the same effect, as if the sequences are entered on the alarm system keypad. Type the instruction as:

yyyyy *PRG* seq,seq,seq,

where

yyyyy is the remote access code; factory default setting is 0000 (4 zeros); the code can be changed, see section 5.4

PRG is the command identification

seq are the programming or operating sequences, consisting of characters 0 to 9, F, N. There can be more than one sequence in one SMS. The particular sequences should be separated with a comma or dot. The number of sequences in one SMS is limited by the maximum size of the SMS in the GSM network.

* separating character, which can be replaced by a space

Example: if the control panel is disarmed and its Installer code is 6060, then the duration of the alarm can be programmed to 5 minutes and the acoustic indication of the exit delay can be disabled by sending the following SMS:

0000 PRG F06060,225,330,N

After receiving the SMS command the control panel will first go to the programming mode (F06060) then sequences 225 and 330 will be performed and in the end the programming mode will be exited (N).

2.10 Alarm system remote control from a telephone keypad

If you want to operate the alarm system from a phone (mobile or landline), perform the following:

- Dial the alarm system number. An attached telephone will ring
- If the phone is not answered, the system will answer after 25 seconds - indicated by a short beep
- Enter the remote access code; factory default is 0000 (4 zeros); to change this code see section 5.4
- Confirmation sounds indicate the control panel mode: 1 beep = armed, 2 beeps = disarmed, 3 beeps = programming mode, Siren sound = alarm.
- From this moment the telephone keypad will work as the alarm control panel keypad. Key * is interpreted as F, key # as N.
- Confirmation sounds indicate the control panel mode: 1 beep = armed, 2 beeps = disarmed, 3 beeps = programming mode, Siren sound = alarm.
- To terminate the connection simply hang up. Connection will also be terminated if there is no entry within 60 seconds.

Notes:

- Remote access from a landline is only possible from a phone using tone dialing (DTMF)
- Reaction of the alarm system to incoming calls can be modified: see section 5.3
- It is impossible to operate the system remotely without a valid remote access code (if used).

2.11 Appliance remote control via a telephone keypad

If you want to operate outputs PgX or PgY (e.g. a household appliance) from a phone (mobile or landline), perform the following:

- Dial the alarm system number. An attached telephone will ring
- If the phone is not answered, the system will answer after 25 seconds - indicated with a short beep
- Enter the remote user access code; factory default setting is 1111 ; to change this code see 5.4
- The system will confirm validity of the code with a beep
- From this moment you can operate the PgX and PgY outputs by entering:
 - [80]** to switch off
 - [81]** to switch on (permanently)
- To terminate the connection simply hang up. Connection will also be terminated if there is no entry within 60 seconds.

Notes:

- Remote access from a land line is only possible from a phone using tone dialing (DTMF)
- Reaction of the system to incoming calls can be modified: see section 5.3
- If the system is not allowed to control without code, the control sequence must be complete with a user code:
 - *8[user code]1
 - *8[user code]0
- For this function it is necessary that the alarm system supports F 81 and F 80 sequences

3 SMS and audible alarm reports

The factory default settings allow the GSM dialer to send SMS reports and audible warnings when the control panel generates important information (alarms, arming, etc.). It is only necessary to set the telephone numbers which the information should be reported to. To enter these numbers, first enter the programming mode.

If you prefer to report more or different events than the factory default provides, see section 4.

3.1 Telephone numbers entering

The dialer has 8 telephone number memories. Each memory has assigned particular SMS reports and/or audible warning according to the default setting – see table 3.3. By entering a telephone number to a particular memory you are selecting what will be reported to this number:

7t xxx...x F0

Where

t is a memory from 1 to 8
xxx...x is a telephone number (max. 20 digits), enter **F9** before the number, if you need **+** prefix for international calls. To use an SMS terminal or an attached telephone set enter code 001 instead of the telephone number

To disable reporting to a particular number, delete this number memory by entering:

7tF0

where **t** is a memory from 1 to 8

Reports testing:

If you wish to report any alarm, arming and disarming by SMS followed with the notifying call and your mobile phone number is 123456789, then

3.3 Telephone numbers table

Memory	Entering sequence	To this pair of numbers will be sent:	Notes
1	71 _____ F0	- ALARM SMS if there is any alarm in the system (intruder, fire, tamper, panic).	<ul style="list-style-type: none"> Only numbers, which can accept SMS, should be entered for the SMS reports (mobile phones, provider's call centers etc.) Audible warnings can be sent both to the mobile and to the landlines as well The communicator can report all possible events from the alarm system, not only the events listed in the table above. See section 4 for details.
2	72 _____ F0	- Technical SMS about events in the system.	
3	73 _____ F0	- ALARM SMS if there is any alarm	
4	74 _____ F0	- ALARM CALL notifies the called person (if you answer such a call, you will hear an audible warning).	
5	75 _____ F0	- ALARM, ARMING & DISARMING SMS.	
6	76 _____ F0	- ALARM CALL notifies the called person (if you answer such a call, you will hear an audible warning).	
7	77 _____ F0	- Technical SMS about events in the system.	
8	78 _____ F0	- ALARM CALL notifies the called person (if you answer such a call, you will hear an audible warning). This setting is suitable to notify landline numbers. - Technical SMS about events in the system. This position is reserved only for service organization.	

enter **75123456789F0** (while the control panel is in programming mode). Then exit the programming mode by **N** key pushing. Now you can arm the system and your mobile phone will receive a reporting SMS.

3.2 Installation name in SMS reports

Each reporting SMS message starts with: "Alarm system reports:". You can change this default title text by sending to the dialer following text programming SMS:

yyyyy*TXT*700,text

where

yyyyy is the remote access code; factory default is 0000 (4 zeros); the code can be changed, see 5.4
TXT is the text programming command
700 is the installation name text index
, comma (separator)
text is your new installation name. A comma or dot cannot be used inside the text. A blank space inside the text is a valid character (dialer ignores spaces before the separator)
***** separating character, which can be replaced by a space

Example: If there is the default code in the dialer, then sending of SMS:

0000 TXT 700,Jewelry shop of Mr. Diamond reports:

to the dialer will change the installation name to the above text.

Note: all the SMS texts stored in the dialer can be changed in a similar way, see section 4.2 for details.

4 Customization of SMS and audible reports

The default text and audible reports sending can be modified.

- The dialer can report all possible events of the alarm system by SMS (see table 4.1.1).
- It is possible to set which events will be reported to which telephone number.
- There are factory default SMS texts available for all possible events and for all possible event sources. All these texts can be edited.
- It is possible to set which events should activate audible warnings.
- The communicator can report all possible events by dialing programmed numbers and playing an audible warning - in the case that the call is answered
- It is possible to change incoming SMS instruction texts, which are used for remote control the system.

First enter the programming mode if you are going to use the following programming sequences:

4.1 Events to be reported by SMS

Table 4.1.1 shows the complete list of all possible events in the alarm system. It also shows which events are assigned to which telephone numbers to be reported by SMS. You can make your own setting by:

81 uu t y

4.1.1 Table – SMS reports assignments to telephone numbers

Event index uu	Event	Telephone numbers							
		1	2	3	4	5	6	7	8
01	Intruder alarm – instant zone	x	x	x	x	x	x		
02	Intruder alarm – delayed zone	x	x	x	x	x	x		
03	Fire alarm	x	x	x	x	x	x		
04	Panic alarm	x	x	x	x	x	x		
05	Wrong access code alarm	x	x	x	x	x	x		
06	Alarm after power on	x	x	x	x	x	x		
07	Tamper alarm	x	x	x	x	x	x		
08	Tamper OK								
09	Alarm end								
10	Alarm canceled by a user	x	x	x	x	x	x		
11	Arming					x	x		
12	Disarming					x	x		
13	Partial arming (Home)					x	x		
14	No code arming					x	x		
15	External communication failure	x	x	x	x	x	x		x
16	External communication recovery								
17	Failure	x	x	x	x	x	x		x
18	Failure recovery								
19	AC failure longer than 30 minutes	x	x	x	x	x	x		x
20	AC failure								
21	AC recovery								
22	Battery failure	x	x	x	x	x	x		x
23	Battery recovery								
24	Enter programming mode								
25	Exit programming mode								
26	Remote access								
27	Remote access – end								
28	RF jamming								
29	Internal communication failure	x	x	x	x	x	x		x
30	Internal communication recovery	x	x	x	x	x	x		x
31	Periodic test								

The **x** marks in the table show which events are assigned to the telephone numbers for the SMS reporting. If you modify these, we recommend you to mark your setting in the table.

4.2 SMS texts editing

The list of SMS texts stored in the dialer consists of texts reported as event reports (installation name, events name and source name) and texts for remote control instructions. All these texts can be changed by the following SMS form:

yyyyy*TXT*y,text, y,text,.....

where

- yyyyy** is the remote access code; default setting is 0000 (4 zeros); the code can be changed, see 5.4
- TXT** is the text programming instruction
- y** is the text index (from 1 to 711, see table 4.2.1).
- ,** comma (separator)

where

- uu** is an event index from 01 to 31
- t** is a telephone number memory from 1 to 8
- y** **0** = reporting disabled, **1** = reporting enabled

Note: SMS reports consist of 4 text parts (installation name, event's name, source name and time) – all of these texts can be edited, see section 4.2 for details. In 1 SMS there can be up to 160 characters using ASCII format otherwise only 70 characters or the SMS message will be split.

The event “ Internal communication failure” is generated if any of wireless detectors are lost under RF supervision.

The event “External communication failure” is generated if there is a GSM signal outage longer than 15 minutes. The release of this event is possible when the GSM signal monitoring is set on.

Example: if you enter **810381** and a Fire alarm is triggered (event index 03) by detector number 1, the following message will be sent to the 8th telephone number: “Alarm system reports: Fire alarm Wireless detector #1 Time: 16.04. 11:16”

text is the new text string. Neither a comma nor a period can be used inside the text. Space inside the text is a valid character (dialer ignores spaces out of the “text” string)

Note: a single TXT type SMS can change more than one text (limited by the maximum size of the SMS in the GSM network).

Example: If the factory default code in the dialer is 0000 (four zeros), then the sending of SMS:

0000*TXT*201, uncle Sam's controller, 202, aunt Mary's controller to the dialer will change the names of remote controllers number 1 and 2.

4.2.1 Table – complete list of SMS texts

Text index y	Factory default text	Text index y	Factory default text
1	Intruder alarm – instant zone	403	Wireless detector #3
2	Intruder alarm – delayed zone	404	Wireless detector #4
3	Fire alarm	405	Wireless detector #5
4	Panic alarm	406	Wireless detector #6
5	Wrong access code alarm	407	Wireless detector #7
6	Alarm after power on	408	Wireless detector #8
7	Tamper alarm	409	Wireless detector #9
8	Tamper OK	410	Wireless detector #10
9	Alarm end	411	Wireless detector #11
10	Alarm canceled by a user	412	Wireless detector #12
11	Arming	413	Wireless detector #13
12	Disarming	414	Wireless detector #14
13	Partial arming (Home)	415	Wireless detector #15
14	No code arming	416	Wireless detector #16
15	External communication failure	501	User code #1
16	External communication recovery	502	User code #2
17	Failure	503	User code #3
18	Failure recovery	504	User code #4
19	AC failure longer than 30 minutes	505	User code #5
20	AC failure	506	User code #6
21	AC recovery	507	User code #7
22	Battery failure	508	User code #8
23	Battery recovery	509	User code #9
24	Enter programming mode	510	User code #10
25	Exit programming mode	511	User code #11
26	Remote access	512	User code #12
27	Remote access – end	513	User code #13
28	RF jamming	514	User code #14
29	Internal communication failure	600	Control panel status:
30	Internal communication recovery	601	Armed
31	Periodic test	602	Disarmed
101	Control panel	603	Exit delay
102	Subsystem	604	Entrance delay
103	Wireless siren	605	Alarm
104	GSM dialer	606	Programming mode
105	Digital line	607	User mode
110	Master code	608	Partially armed
201	Controller #1	609	Battery failure
202	Controller #2	610	Tamper alarm
203	Controller #3	611	Alarm memory
204	Controller #4	612	System failure
205	Controller #5	613	Power supply failure
206	Controller #6	614	Control panel status unknown
207	Controller #7	621	Time:
208	Controller #8	622	Last event:
301	Wired detector #1	623	SMS processing failure.
302	Wired detector #2	624	Credit unknown
303	Wired detector #3	625	<i>Text will be inserted by instruction CREDIT (see 5.14)</i>
304	Wired detector #4	650	SMS processed successfully.
305	Wired detector #5	651	Wrong SMS processing.
306	Wired detector #6	653	AUX switched ON
307	Wired detector #7	654	AUX switched OFF
308	Wired detector #8	700	Alarm system reports:
309	Wired detector #9	703	AM
310	Wired detector #10	704	DM
311	Wired detector #11	705	MO
312	Wired detector #12	706	ME
313	Wired detector #13	707	AUXON
314	Wired detector #14	708	AUXOFF
315	Wired detector #15	709	CREDIT
316	Wired detector #16	710	PGON
401	Wireless detector #1	711	PGOFF
402	Wireless detector #2		

4.2.2 Editing of remote control SMS commands

If you change any of the text strings from 703 to 711, the dialer will recognize the new text string as the valid remote control command. E.g., if you change text “MO” (number 705) to “Tell me please my alarm status” it will be possible to read the control panel status by sending new string as the SMS command. This function helps customer to keep the commands secret and protect the dialer against unauthorized operating.

4.3 Assignment of audible warnings to be reported

Table 4.3.1 shows the complete list of all possible events in the alarm system. It also shows which events are assigned to which telephone numbers to be reported audibly. You can make your own setting by:

82 u u t y

where

- uu** is an event index from 01 to 31
- t** is a telephone number memory from 1 to 8
- y** 0 = reporting disabled, 1 = reporting enabled

4.3.1 Table – audible warning assignments to telephone numbers

The x marks in the table show which events are assigned to the telephone numbers to be reported audibly. If you modify these, we recommend you mark your setting in the table. If there is the alarm siren sound will be played, in case of other events a melody sound will be played.

Event index uu	Event	Telephone numbers							
		1	2	3	4	5	6	7	8
01	Intruder alarm – instant zone			x	x	x	x	x	
02	Intruder alarm – delayed zone			x	x	x	x	x	
03	Fire alarm			x	x	x	x	x	
04	Panic alarm			x	x	x	x	x	
05	Wrong access code alarm			x	x	x	x	x	
06	Alarm after power on			x	x	x	x	x	
07	Tamper alarm			x	x	x	x	x	
08	Tamper OK								
09	Alarm end								
10	Alarm canceled by a user								
11	Arming								
12	Disarming								
13	Partial arming (Home)								
14	No code arming								
15	External communication failure								
16	External communication recovery								
17	Failure								
18	Failure recovery								
19	AC failure longer than 30 minutes								
20	AC failure								
21	AC recovery								
22	Battery failure								
23	Battery recovery								
24	Enter programming mode								
25	Exit programming mode								
26	Remote access								
27	Remote access – end								
28	RF jamming								
29	Internal communication failure								
30	Internal communication recovery								
31	Periodic test								

Example: if you enter **820381** and a Fire alarm is triggered (event index 03) the dialer will call the 8th telephone number and it will play audible warning if the call is answered.

4.4 SMS and audible reports permit

If you need to disable all SMS and audible reports temporarily to all telephone numbers, use the following sequence:

801 all reports enabled
800 all reports disabled

Default setting: all reports enabled (801).

5 General settings

Firstly enter the programming mode if you are going to use any of the following sequences.

5.1 Use of the SIM card with a PIN code

It is recommended to use the SIM card with the PIN code protection disabled (this can be done with a mobile phone, see section 1). If you insist to use the PIN code, enter it after the GSM dialer powering on by:

70 xxxx F0

where:

xxxx is the PIN code (4 digits)

Example: if the PIN code is 1234 enter 701234F0

Default setting: 70F0 the PIN code protection is off

Note:

- If the dialer does not enter the GSM network after powering on (LED starts flashing), there is a probability that a wrong PIN code was set. In this situation:
 - enter 70F0 on the control panel keypad when in the programming mode (PIN code erasing in the dialer)
 - disconnect the control panel's power supply (AC and battery)
 - remove the SIM card, insert it into a mobile phone and check the PIN code. Check also that it is possible to enter the desired GSM network in the location of the dialer GSM antenna.

- if you are sure the PIN code is right and the location is covered with a GSM signal, insert the SIM card back to the dialer, switch the power supply on, enter the PIN code (70 PIN F0) and wait until the communicator enters the GSM network (LED will turn off).
- If you are going to change a current SIM card in the dialer for another one and the former one used a PIN code, open programming mode at first and enter 70F0 (PIN code erasing in the dialer).

5.2 GSM signal checking

If this function is enabled, the dialer will check regularly whether the GSM signal is available. If it is not ready for more than 15 minutes, the system will indicate an external communication failure (failure L).

910 checking disabled
911 checking enabled

Default setting: checking disabled (910)

5.3 Reaction to an incoming call (remote access)

This sequence sets how the dialer will react to incoming calls. This setting is important for the remote access from a telephone.

93 x

where

- x = 0** no reaction to an incoming call
- x = 1 to 8** will answer after 1=5sec., 2=10sec.,..., 8=40 seconds
- x = 9** will answer after the second call = after the 1st ring is detected, there must be a pause of 10 - 45 seconds. The dialer will answer on the very first ring of the second call. This setting can be used to bypass an answering machine connected to the phone output.

Default setting: 935 – the communicator will answer after 25 seconds

5.4 Remote access codes setting

These sequences program:

5.4.1 Service remote access code

94 xxxxxxxx F0

where

xxxxxxx is the code, it can have from 1 to 8 digits

If you enter **94F0** - the code will be erased and the remote access to the alarm system **will be not allowed**.

Default setting: 0000 (4 zeros)

5.4.2 User remote access code

94 xxxxxxxx F1

where

xxxxxxx is the code, it can have from 1 to 8 digits

If you enter **94F1** - the code will be erased and the user remote access to the alarm system **will be not allowed**.

Default setting: 1111

5.5 Confirmation SMS reply messages

After a valid incoming SMS command processing, the dialer replies to the sender with a confirmation SMS message automatically. This confirmation is selectable:

950 automatic reply is disabled

951 automatic reply is enabled

Note: if the automatic reply is disabled, you can request a reply manually by adding a space and letter C after the last character of the SMS instruction.

Default setting: 951 – automatic reply is enabled

5.6 Reset to default settings

Entering **96060** will cause the return to the default settings (all telephone numbers will be erased, all non sent data will be erased and factory default SMS texts will be reloaded).

5.7 Total reset – all communications disabled

Entering **96061** will erase all of the settings in the dialer's memory and the list of SMSs will be set to default setting.

5.8 One-time dialing-in when in programming

While the control panel is in the programming mode, you can enable one-time remote access by entering **970**. After this code is entered, the dialer will respond to the first ring of any incoming call. Not requesting the access code it will enable the calling phone keypad to be used as the keypad of the alarm system (* = F, # = N).

The immediate dialing-in will be disabled after you dial-in, or after you exit the programming mode.

5.9 GSM signal monitoring

Enter **971** on the alarm system keypad (when in programming mode) to measure the GSM signal strength. The keypad will show a number from 0 to 9 and it will sound a beep every second indicating a new measurement. For proper functioning of the module the signal strength should be 3 or higher. Find the best location for the antenna while measuring the signal strength. To switch the system **back to the programming mode** press the **N** key.

Note: As the equipment of the JA-60GSM is supplied the antenna with +3dB gain.

JA-60GSM communicator module

5.10 Attached phone function

The dialer provides a PHONE output to connect an ordinary telephone set. Function of this telephone can be modified by entering:

98 y

where	function
y = 0	ordinary telephone line is simulated, it is possible to make phone calls (indicated with a dial tone in the receiver)
y = 1	if you pick up the receiver, the telephone keypad will work as the keypad of the alarm system. It is impossible to make phone calls in this mode (you will hear sounds of the alarm keypad in the receiver)
y = 2	disabled - the telephone has no function
y = 3	emergency call – if you pick-up the phone, it will dial the emergency number (see 5.11) automatically

Notes:

- If $y=0$ and you pick-up the phone, the telephone keypad can be switched to the alarm system keypad mode by pressing key #.
- If $y=3$ and you press key * within 2 seconds after you pick up the phone, you will hear the dial tone and you can call any number. If key # is used the same way, the keypad will switch to the alarm system keypad mode.

Default setting: $y = 0$ ordinary telephone line is simulated

5.11 Emergency call number entering

If the attached telephone is programmed for emergency calls (see section 5.10), it dials the emergency number after you pick up the receiver. This number can be entered by:

99 xx...x F0

where:

xx...x is a telephone number (max. 20 digits), enter **F9** before the number if you need + prefix for international calls

Default setting: no phone number is set (99F0)

5.12 Function of attached SMS terminal

The communicator has a telephone connector, which can be used for connection to a MT-77 Piccolo terminal. A detail description is in the separate manual enclosed with the Piccolo terminal. To use an SMS terminal or an attached telephone set enter code 001 instead of the telephone number (see chapter 3.1)

Setting:

- For sending SMSs it is necessary to set 1111 telephone number of the SMS center at the position 1.
- By sending number 001, the central panel can be controlled using the SMS instructions

Note:

- Displaying of the caller's telephone number (CLIP). The telephone number is shown in the international format (004202 12345678). The Piccolo can auto-dial back to the caller's number.
- If the phone call is made from a JA-60GSM a telephone number of 001 and name of the caller "JA-60GSM" will be

5.13 Sustain calls for prepaid SIM cards

If a prepaid card is used, the dialer can automatically perform a sustain call when there was no call within a 3 month period. It will dial the programmed number and after a 10 second call duration the dialer will hang up. The number, which should be called, can be entered by:

973 xxxxxxxx F0

where: xxxxxxxx is the telephone number (max. 20 digits) – it is recommended to call a time information service, etc.

5.14 Prepaid SIM cards

The JA-60GSM communicator can send information about the credit balance of a prepaid SIM card. An SMS sent from any of the stored numbers (sequence 7t...) containing the word CREDIT followed by the correct instruction (different for every provider) will result in the sending of the information about the credit. Please ask your mobile phone provider for more information.

CREDIT *xxxxx# where **xxxxx** is a string, which depends on the GSM provider. Ask your provider for more details

If you want to check the credit regularly use the following sequence.

CREDIT uuu..u xx yyz

where: **uuu..u** is the instruction given by the provider for receiving information about the amount of credit
xx is the time period (in days) for checking.
yy is minimum level of credit
zz is a position of the credit in the information SMS sent by the provider

If the level of the credit is lower than set value (zz) the event "battery discharged GSM communicator" will be sent to the preset telephone numbers. If the credit is restored the event "battery OK GSM communicator" will be sent to the preset telephone numbers. To disable this function set the time (xx) period to 00.

Note:

- The user is responsible for the level of the credit
- **The producer does not recommend the use of prepaid cards.**

Whereas the dialer does not draw any user's attention to petered out credit, the user must check the credit himself. Besides this, most of GSM providers demand regular credit recharging. Therefore a prepaid SIM card is not recommended.

5.15 Attached telephone volume

The volume and sensitivity of the attached telephone can be adjusted by:

- 974x** receiver volume
- 975x** microphone sensitivity

where **x** can be from 1 to 9 (factory default is 5 for both)
 If the system is in programming mode, the volume can be adjusted during a phone call.

5.16 GPRS communication setting

GPRS can be used for communication with a www server, for connecting a PC to the internet or for communication to a CMS. GPRS must be activated on the SIM card (for detail information ask you GSM provider). Also it is necessary to set in the communicator name APN using the ComLink software.

6 Web server remote access

6.1 Setting possibilities

The setting server allows a user to read and change the control panel and dialer configuration. Data transfer is made by sending an SMS or GRPS. The web site allows the changing of:

- control panel setting
- dialer setting
- editing of SMS reports
- the monitoring station setting

The web site is able to read the event memory of the control panel as well. The number of sent data SMSs is optimized to reduce costs as much as possible. GPRS data transfer can be used, but must be activated on the SIM card.

6.2 Registration to the web site

The registration can be performed in two ways:

Web site www.gsmlink.cz – to register your system use the registration code printed in the warranty certificate (the code has a form xxxx-xxxx-xxxx and it is a unique for each system).

Mobile phone – when the alarm system is in programming mode, enter 972 xxxx F0 on the alarm system keypad (xxxxx is your mobile phone number). After a moment you will receive an SMS with registration code and the system will register to the web server.

7 Central Monitoring Station communication setting

The dialer can report events to two different Central Monitoring Stations (here and after CMSs). Each CMS has its own setting sequences that differ in parameter **p** (p=1 for CMS1 and p=2 for CMS2). The dialer uses Ademco Contact ID format and it is also equipped for future use of GPRS data transfers. The product is ready to report events to a CMS based on either landline or GSM data transfer.

7.1 CMS phone numbers entering

Primary and back up telephone numbers can be entered for each CMS:

Primary number: **01 p xx....x F0**
 Back up number: **02 p xx....x F0**

where:

- xxx...x** is a telephone number, max. 20 digits
- p** 1=CMS1, 2=CMS2

Example: 123456789 can be entered as the CMS2 primary number by entering: 01 2 123456789 F0

CMS phone number erasing is possible by entering **01pF0** or **02pF0**. There will be no transfer to a CMS if its numbers are erased.

Default setting: No phone number is set

7.2 Account ID setting

A CMS uses this ID number for the alarm system identification:

03 p zzzz F0

where:

- zzzz** is the account ID number (z = numbers from 0 to 9 or A=F1, B=F2, C=F3, D=F4, E=F5 a F=F6)
- p** 1=CMS1, 2=CMS2

Default setting: ID is 0000 for both CMSs

7.3 Format setting

This sequence is used to select the communication format:

04 p x

where:

- p** 1=CMS1, 2=CMS2
- x** protocol type – see table

Protocol	Type	x
Contact ID	DTMF	0
Jablotron SMS	SMS type	1
Jablotron GPRS	GPRS type	2

Default setting: Contact ID for both CMSs

7.4 Events to be reported to CMS

There are 31 types of events, which can be reported to each CMS – see table 7.4.1. This sequence sets which events should be reported to CMSs.

05 p uu y

where

- p** 1 = CMS1, 2 = CMS2
- uu** events index – see table 7.4.1
- y** 0 = report disabled, 1 = report enabled

Default setting: all reports are disabled

7.4.1 Table – complete list of events to be reported to CSM

Events index uu	Events description
01	Intruder alarm – instant zone
02	Intruder alarm – delayed zone
03	Fire alarm
04	Panic alarm
05	Wrong access code alarm
06	Alarm after power on
07	Tamper alarm
08	Tamper OK
09	Alarm end
10	Alarm canceled by a user
11	Arming
12	Disarming

13	Partial arming (Home)
14	No code arming
15	External communication failure
16	External communication recovery
17	Failure
18	Failure recovery
19	AC failure longer than 30 minutes
20	AC failure
21	AC recovery
22	Battery failure
23	Battery recovery
24	Enter programming mode
25	Exit programming mode
26	Remote access
27	Remote access – end
28	RF jamming
29	Internal communication failure
30	Internal communication recovery
31	Periodic test

7.5 CMS re-dialing pause setting

If the dialer is activated it attempts to make a connection (alternating between the primary and the backup telephone number). If it is not possible to make a connection, a pause is initiated. After this pause the dialer will attempt again. The pause length can be set in the following way:

06 p t

where

t pause duration x 5 minutes (1 = 5 minutes, 2 = 10 min, ..., 9 = 45 minutes)
p 1 = CMS1, 2 = CMS2

Default setting: 5 minutes for both CMSs

7.6 Interval of periodic test

The periodic test is set by activating event No 31. The following sequence sets the time length from the last reported event to the moment when the periodic test should be transferred.

07 p hhmm

where

p 1 = CMS1, 2 = CMS2
hh hours
mm minutes

Default setting: Periodic test is sent after 24 hours from the last event.

7.7 CMS communication disabling

If you need to disable all CMS reports temporarily, you can do this, while retaining your settings:

00 p 0 all reports to CMS **p** disabled
00 p 1 all reports to CMS **p** enabled

Default setting: all CMS reports disabled.

7.8 CMS 2 as a back up of CMS1

The CMS 2 can serve as an optional back up data transfer to CMS if the data transfer of CMS1 fails.

080 CMS1 and CMS2 are two independent stations

081 CMS 2 works as a back up transfer

When 081 selected, the CMS 2 settings are used only in case of failure of CMS 1 transfer.

Default setting: two independent CMSs.

8 The modem function

The GSM communicator can also be used as an external modem for accessing the Internet (GPRS format). It is necessary to have the GPRS in the SIM card activated and to have a connection cable connected to the COM port of the PC. Support for MS Windows operating systems can be found on the enclosed CD. The modem can be used only when all reports to the CMS, SMS and system's calls are executed.

When the modem is used:

- It is possible to use the attached telephone, the internet connection will be temporarily suspended
- Received SMS's are stored and they will be processed after disconnection of the modem
- The modem will be disconnected if an alarm or arming event occurs

9 Additional information

9.1 Priorities of Events reporting:

If the dialer is activated to send an events report it will:

- send information to CMS1 (trying primary and back up numbers two times) if programmed
- send information to CMS2 (trying primary and back up numbers) if programmed
- send SMS reports (1st telephone number, 2nd telephone number, ..., 8th tel. number)
- send audible reports (1st telephone number, 2nd telephone number, ..., 8th tel. number) – each number is called only once, no matter if it was answered or not
- if the attempt to send a report to a CMS was not successful, the dialer will try to send it again after the re-dialing pause (sequence 06px). The dialer will make three attempts at sending event reports to a CMS, i.e. it will wait (according to the setting 06px) twice for the re-dial pause. Only a new event will result in an additional attempt to call the CMS.

If any event is triggered which should be reported to a CMS while the alarm system is accessed remotely from a phone, the report will be sent after the remote access is finished.

If a user cancels an alarm, all reports, which haven't been sent yet, will be deleted. This doesn't concern communication with the CMS.

9.2 LED on the dialer PCB

- LED is flashing – the dialer has not entered the GSM network
- LED if flashing (3x) – communicator (modem) is controlled from PC.
- LED is on – communication with GSM network
 - entering the GSM network
 - dialer is calling
 - dialer is sending SMS

9.3 Entering the programming mode

- Dialer will finish current CMS connection
- Current audible warning is interrupted immediately
- SMS and audible warning, which remain unsent before the entering of the programming mode, are erased – they will not be sent after exiting the programming mode
- Unsent event reports to a CMS are erased only in case of a telephone number, account ID or communication format change
- Information about the end of faulty events is transferred to the monitoring station during the programming mode
- Changes in the setting will take affect after finishing the service mode

9.4 Owner of Master code can change these parameters

- Telephone numbers 1 – 7 (see section 3.1)
- SMS and audible warning transfer (see section 4)
- Change remote user code
- One-time dialing in
- Measuring of GSM signal
- Attached phone function
- Telephone number for emergency call

10 Technical specifications

power	12VDC / max. 1A – provided by the alarm control panel
GSM bands	E-GSM/GPRS 900/1800MHz
transmitted power	2 W for GSM900, 1 W for GSM1800
AUX output	dry contact, max. 100mA / 60V
comply with	EN 50131-1, EN 50136-2-1, 2-3, 2-4
security grade	2 (low to medium risk)
environmental class	II indoor-general (–10 to 40°C)
safety	EN 60950
EMC	EN 301489-1, EN 301489-7, EN 55022, EN 50130-4
radio characteristics	ETSI EN 301419-1, EN 301511
Caller line identification presentation (CLIP)	ETSI EN 300 089 V3.1.(2000-12)
Can be operated according to commission decision 2000/299/EC	

Hereby, Jablotron Ltd., declares that this JA-60GSM is in compliance with the essential requirements and other relevant provisions of Directive 1999/5/EC.



Original of the conformity assessment can be found at the web page www.jablotron.cz, section Technical support.

Note: Although this product does not contain any harmful materials we suggest you to return the product to the dealer or directly to the producer after usage.

11 Brief list of programming sequences

Function	sequence	options	factory default
Tel. numbers for SMS and audible reports	7t xxx..x F0	t = memory from 1 to 8 xxxx = tel. number (max.20 digits), F9="+"	blank
Events SMS reports	81 uu t y	uu = events index from 01 to 31 t = memory from 1 to 8 y=0 disabled, y=1 enabled	t=1&2 alarm SMS
Events acoustic reports	82 uu t y		t=3&4 alarm SMS + audible t=5&6 alarm+arming SMS + audible t=7&8 audible alarm only
SMS and audible reports SW	80 y	y=0 disabled, y=1 enabled	enabled
GSM signal checking	91 y	y=0 disabled, y=1 enabled	disabled
Incoming call reaction	93 x	x = 0 no reaction x = 1 to 8 answer after 5 to 40 seconds x = 9 answer after the 1 st ring of the 2 nd call	after 25 seconds
Service remote access code	94 xxxxxxxx F0	xxxxxxxx = code, it can have form 1 to 8 digits deleting - 94F0 - remote access is not possible	0000
User remote access code	94 xxxxxxxx F1	xxxxxxxx = code, it can have form 1 to 8 digits deleting 94F1 - remote access is not possible	1111
Confirmation SMS reply	95 y	y=0 disabled, y=1 enabled if disabled, end instruction with C to get the reply	enabled
Reset	96060	Reset to factory default settings	
Reset & no reports	96061	Reset to factory default settings & all reports disabled	
Immediate dialing-in	970	If entered while in programming, you can dial-in after the 1 st ring without the access code	
Measuring of GSM signal	971	If entered while in programming, it shows GSM signal strength (from 0 to 9)	
Volume adjustment of connected phone	974x 975x	Level adjustment of received and outgoing signal (from 1 to 9)	5 – medium level
Attached phone function	98 y	y=0 telephone line y=1 alarm keypad y=2 no function y=3 emergency call	telephone line
Emergency call number	99 xxxxxx F0	xxxxxx = tel. number (max.20 digits), F9="+"	erased
CMS telephone numbers	0y p xxxxx F0	y=1 primary number, y=2 back up number p=1 CMS1, p=2 CMS2 xxxx = tel. number (max.20 digits), F9="+"	all erased
Account ID	03 p zzzz F0	p=1 CMS1, p=2 CMS2 zzzz account ID, z=0 to 9 or A=F1, B=F2, C=F3, D=F4, E=F5 a F=F6	0000 for both CMSs
CMS protocol	04 p x	p=1 CMS1, p=2 CMS2 x=0 CID, x=1 SMS, x=2 GPRS	CID for both CMSs
Events to report	05 p uu y	p=1 CMS1, p=2 CMS2 uu = events index from 01 to 31 y=0 disabled, y=1 enabled	all reports disabled
CMS redialing pause	06 p t	p=1 CMS1, p=2 CMS2 t=1 to 9 (x 5minutes)	5 minutes
Periodic test interval	07 p hh mm	p=1 CMS1, p=2 CMS2 hh mm hours minutes	24hr. after the last report
CMS reports SW	00 p y	p=1 CMS1, p=2 CMS2 y=0 disabled, y=1 enabled	disabled for both CMSs
CMS2 as a backup of CMS1	08 y	y=0 two independent CMS y=1 CMS2 is a backs up of CMS1	two independent CMS