

# JA-65 "MAESTRO" Alarm system Installation manual

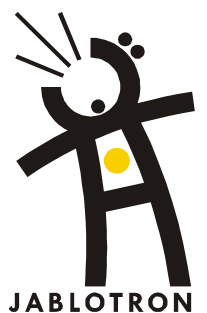
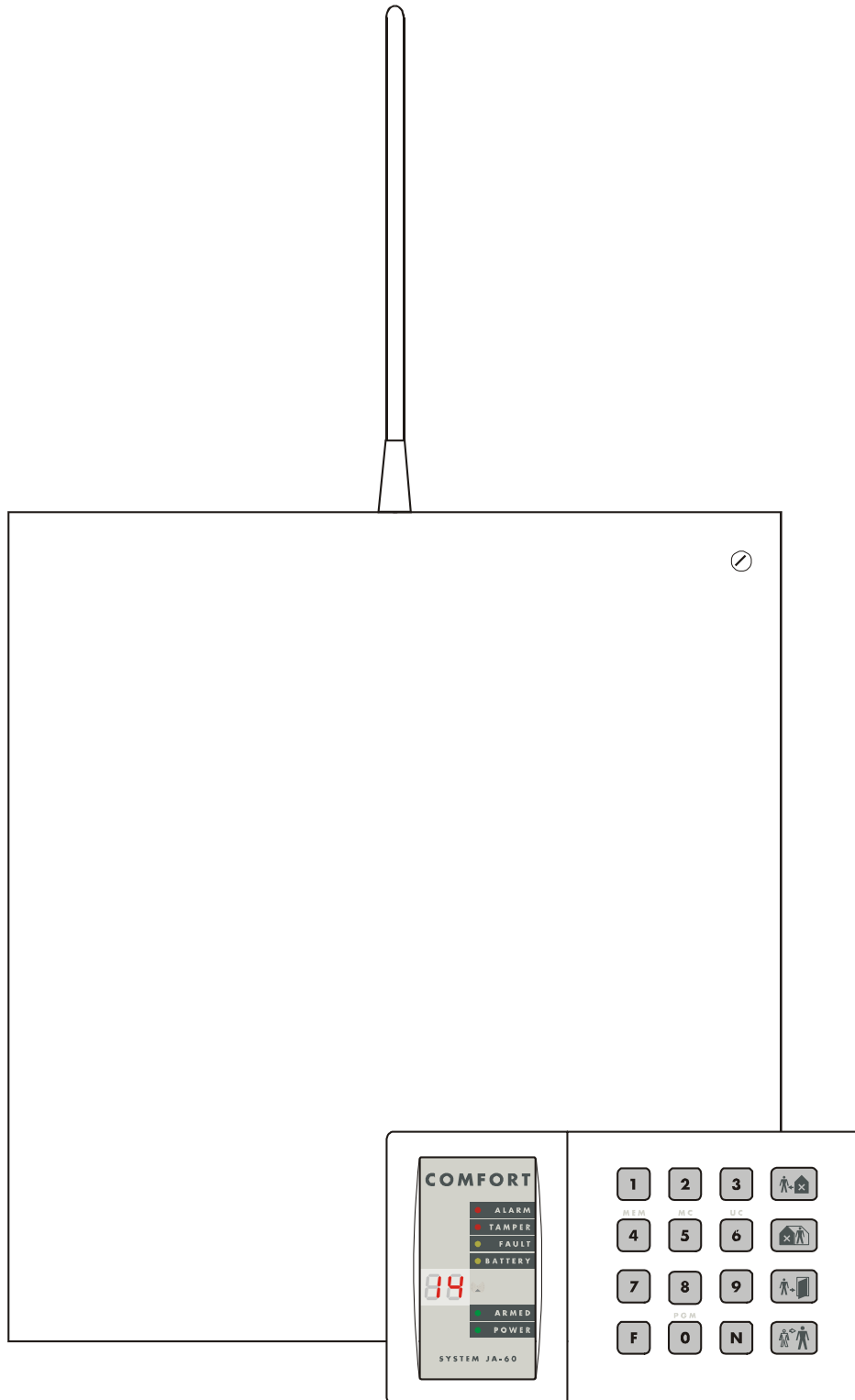

*This manual is valid for control panel model JA-65 versions FM61114 (control panel board) and DY6132 (telephone communicator board).*

*The use of Comlink Windows v. 57 software or higher is required for this control panel and can be obtained from our home page at [www.jablotron.cz](http://www.jablotron.cz)*

## Contents:

<b>1. Architecture of the control panel</b>	<b>4</b>
<b>2. Configuration of the control panel</b>	<b>5</b>
<b>3. Control panel installation</b>	<b>5</b>
3.1. Power cable wiring	5
<b>4. Antenna of the JA-65R module</b>	<b>5</b>
4.1. Rubber antenna use in the control panel	5
4.2. External antenna use	6
<b>5. Connection of a telephone line to the JA-65X module</b>	<b>6</b>
<b>6. Connectors and terminals of the main board</b>	<b>6</b>
<b>7. The JA-65H hard wired input module terminals</b>	<b>7</b>
<b>8. Wiring of the JA-60 keypad(s)</b>	<b>8</b>
<b>9. Installation of wireless items</b>	<b>8</b>
<b>10. Back up battery installation</b>	<b>8</b>
<b>11. First powering of the control panel</b>	<b>8</b>
<b>12. Control panel programming</b>	<b>9</b>
12.1. Enrollment (teaching) of wireless items	10
12.2. Hard-wired zone input setting	11
12.3. Exit / Entrance delay	11
12.4. Alarm duration	11
12.5. PgX and PgY output functions	11
12.6. Recorded message and phone number editing in the user mode	12
12.7. Radio signal jamming testing	12
12.8. Regular communication checking	12
12.9. Reset enabled	12
12.10. Controlling of a subsystem sequence: 2 9 0	13
12.11. Enrollment of the control panel to a UC-2xx or to a master control panel	13
12.12. No code requested for F1, F2, F3, F4, F8 & F9	13
12.13. Partial (Home) arming with (F2) (non split control panel)	13
12.14. Hard wired siren alarm enabled	14
12.15. Exit delay audible indication	14
12.16. Partial arming exit delay audible indication	14
12.17. Entrance delay audible indication	14
12.18. Arming and disarming chirps with hard wired siren	14
12.19. Siren alarm in Disarm & Partial arming	14
12.20. Wireless siren alarm	15
12.21. Indication of system problems when arming	15
12.22. Control panel splitting	15
12.23. Only first source of alarm is recorded	15
12.24. Alarm triggered by opened zone when arming	15
12.23. Addressing of wireless detectors to sections	15
12.24. Addressing of the user codes to sections	16
12.25. Addressing of wireless controllers to sections	16
12.26. Automatic arming / disarming setting	16
12.27. New service code setting	16
12.28. User Mode entering	16
12.29. Real time and date setting	17
<b>13. System testing</b>	<b>17</b>
<b>14. Voice &amp; Pager message setting</b>	<b>18</b>
14.1. Telephone number entering	18
14.2. Voice message(s) recording	19
14.3. Triggering of voice and pager messages sending	19
14.4. Dialing method	20
14.5. Telephone line checking	20
14.6. Telephone dialer testing	20
<b>15. To enable a remote computer to dial in</b>	<b>21</b>
15.1. Reaction to an incoming call	21
15.2. Remote access code setting	21
<b>16. Monitoring station communication setting</b>	<b>22</b>
16.1. Reporting code setting	22
16.2. Account code setting	23
12.3. Protocol and Format setting	23
16.4. Re-dialing pause setting	23
16.5. Phone number entering	24
16.6. Digital communicator reset	24
<b>17. Control panel factory default reset</b>	<b>24</b>
<b>18. Monitoring station report code table</b>	<b>25</b>
18.1. Internal structure of Contact ID protocol	26
<b>19. Personal Computer Interface with PC-60A</b>	<b>27</b>
<b>20. Remote access to the system</b>	<b>28</b>
20.1. Establishing connection with a remote control panel	28
<b>21. Recommended Professional installer basic rules</b>	<b>28</b>
<b>22. Trouble shooting table</b>	<b>28</b>
<b>23. Possibilities to extend the system</b>	<b>29</b>
<b>24. Control panel specifications:</b>	<b>31</b>

This product is to be installed by professional installers only. The manufacturer assumes no liability for damages caused by incorrect installation or improper use of this system.

## 1. Architecture of the control panel

The JA-65 "Maestro" is a fully programmable control panel with building block architecture. This allows the JA-65 to be tailored to particular installation requirements. The Maestro can operate as a wireless, wired or combined system. The JA-65K metal box has a built in electronic power supply. There is space for a 12V, 7Ah back up battery. The 16 zone control panel's main board is installed in the internal platform. The main board does not have any physical zone inputs. This allows you to configure the control panel by using the following modules:

- **Radio communicating module JA-65R** can enroll wireless items (JA-60): up to 16 detectors, up to 8 controllers (remote controls or wireless keypads), JA-60A wireless sirens and UC family wireless output modules.
- **Hard-wired input module JA-65H** has 8 input loops with programmable triggering (NC, balanced or double balanced) and programmable reactions. Up to two JA-65H hard-wired input modules can be used in the control panel.
- **GSM dialer JA-60GSM** sends SMS messages, calls to predefined telephone numbers and plays audible warning, communicates with 2 CMS, allows remote access from a phone's keypad and can be set via web page.
- **Telephone communicator JA-65X** can communicate with a Monitoring Station, send voice messages and dial a numeric Pager. It can also communicate with a remote PC (using ComLink SW and a JA-60U modem).
- **Operation and programming** is possible via the JA-60E keypad (or by its wireless option, JA-60F). The control panel can also be operated by a RC-11, RC-22 or RC-60 remote control, by input loop or by a JA-60D wireless keypad. Operation and programming is also possible via a PC using ComLink SW.

This allows the JA-65 to operate as a wireless (16 detectors), wired (8 or 16 inputs) or combined system. An additional JA-60 or JA-65 subsystem control panel can expand the system. The control panel can be split in to two independent sections with a shared common area.

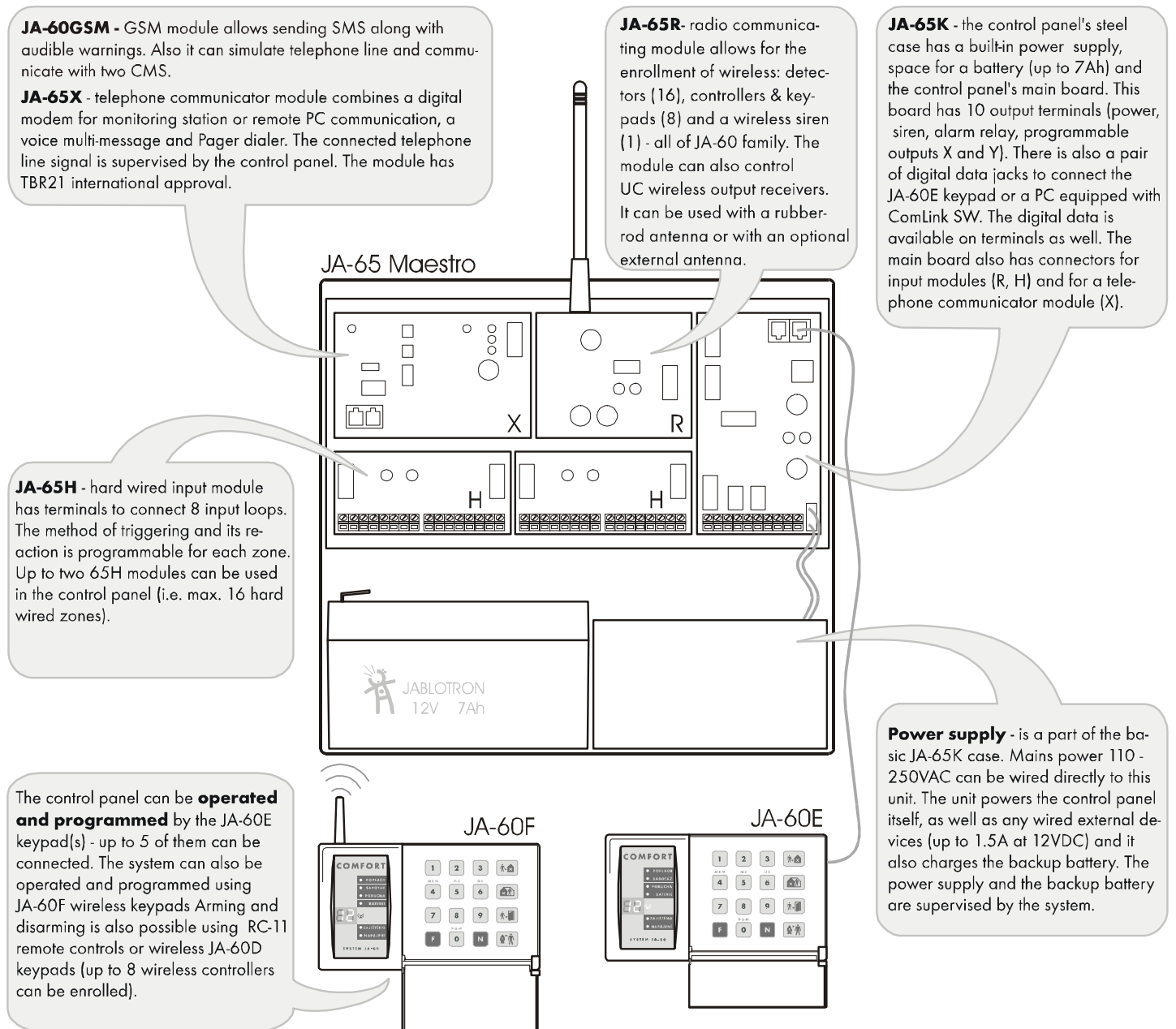

## 2. Configuration of the control panel

The metal case of the JA-65K control panel is shipped from the factory with a built-in power supply unit and the main board. To be able to work as an alarm system, it should be equipped with interface modules (R, H, X) in the following way:

- open the case and remove the cover
- disconnect the power unit cable from the main board connector K5
- unscrew the module platform (screw on the left side)
- open the platform and remove it from the case
- attach the desired modules to the positions shown in the previous diagram
- connect the modules' cables to the main board in the following way:
  - 60GSM or 65X = K1
  - 65R = K2
  - 65H = K3 (if two 65H modules are used, connect the left module cable to the right 65H module and the right module cable to the main board's K3 connector)

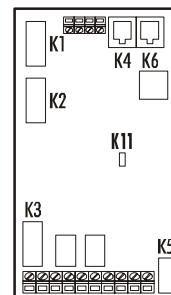

## 3. Control panel installation

The control panel's case is designed to be attached to the wall, or it can be partly installed into the wall. The rectangular hole on the back side is for cable routing. The hole matches a KT-250 standard junction box. This allows for easy specification on how to prepare cables in a house before an alarm system installation.

- If the **65R radio-communicating module** is used, keep in mind that the **antenna will need about 20 cm of clearance**. The 65R module comes with a rubber antenna, but it can also be used with an external antenna, model AN-01. The working range of the wireless accessories is about 100 meters under optimal conditions. However, building materials can absorb or obstruct radio signals and communication can also be effected by interference from other radio signals. For these reasons, you should anticipate a shorter working range for indoor installations.
- Before attaching the case to the wall, remove the power supply unit (two screws from the front side)
- **Route all the cables** to the control panel (power, input loops, outputs, telephone line etc.) before you attach the case to the desired location.

**Note:** if you install the case in the wall, the hinges for both the cover & module mounting platform should not be placed within the wall.

### 3.1. Power cable wiring

**The power cable should be connected only by a licensed electrician.** The control panel is a class II. device with double insulation and power to its power unit must be wired with double insulated two core power cord. No power wire should be connected to the metal case. Instructions:

- use flexible 2 core (size from 0.75 to 1.5 mm<sup>2</sup>) double insulated power cord. The system should not share a fuse (10 A max) with any other household item. The fuse is used as a circuit breaker too.
- route the power cable through the plastic bushing of the power supply unit cover and screw its wires tightly to the AC terminals
- attach the cable firmly to the board using the plastic bracket. Before you tighten the bracket, check that the wires are tightly screwed in the terminals and be sure that the wires are not longer than shown in the diagram.
- reattach the power supply unit in the case, but do not switch the power on
- install the module mounting platform to the case and connect the power unit cable to connector K5 on the main board .

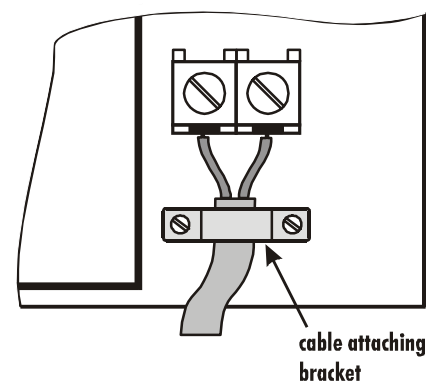

**Warning: never open the cover of the power supply unit when the system is powered!**

## 4. Antenna of the JA-65R module

If the JA-65R module is installed, it will be possible to enroll wireless detectors, controllers, a JA-60A siren, output modules and another wireless subsystem if required. Enrollment is described in the part 9. The 65R module must be equipped with an antenna.

### 4.1 Rubber antenna use in the control panel

There is a hole on the top of the control panel case (remove the plastic cap) for the rubber antenna. The rubber antenna is supplied with the 65R module. Install the antenna after the module mounting platform is inserted and screwed inside the control panel case. Attach the antenna to the 65R board using a screw as shown in the diagram. The antenna must not be obstructed by any large metal object.

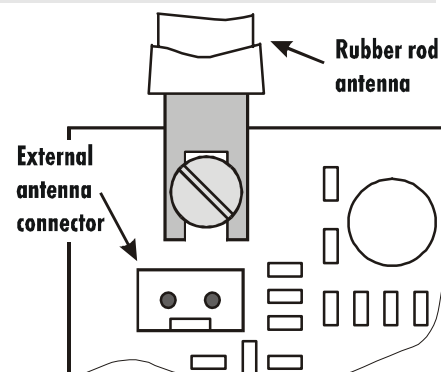

## 4.2 External antenna use

An optional external antenna, model AN-01, can be used with the 65R module. This antenna has a connector, which fits the connector on the 65R module. If you use the external antenna, the rubber antenna should not be installed. The AN-01 antenna has a small plastic ring on its end, used to hang it from the wall. Its active part (from the plastic ring to the coil) should be installed vertically and should not be obstructed by any large metal object. The antenna can be located behind furniture, etc.

## 5. Connection of a telephone line to the JA-65X module

If the JA-65X module is installed, the control panel can communicate with a Monitoring Station, send voice messages and dial a numeric Pager as well as communicate with a remote PC. A standard analog telephone line (type TNV 1-3) must be connected to the 65X module for these functions.

- Use the provided telephone cable to connect the telephone line to the IN jack in the 65X module (see diagram )
- Connect a telephone, fax or other phone operated device to the OUT jack, marked with a phone symbol
- When the control panel is in normal stand by mode, the phone line and any attached device will operate as normal

**Note:** The communicator must be plugged directly to a telephone line socket. All other devices (telephone, facsimile machine, modem etc.) should be connected to the communicator output.

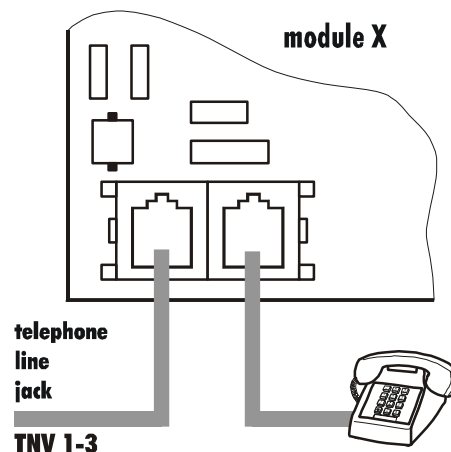

## 6. Connectors and terminals of the main board

In addition to the interface module connectors (K1, K2 and K3) the main board has the following connectors:

**K5 - power supply connector:** the cable from the power unit is connected to this . By disconnecting this cable you completely power-down the system (for example, when you perform a factory default reset).

**K4, K6 - digital data jacks for the JA-60E keypad(s) and/or for a PC interface cable.** Up to five JA-60E keypads can be connected to a JA-65 and the maximum length of the cable can be 500 meters. We recommend use of a CT-04 cable and RJ-44 (Jablotron) crimping connectors to make the keypad cables. The digital data is also available on the terminals: see the following description.

**1,2,3,4** - digital data terminals (see K4, K6) provide an option to use standard cable for the wiring of JA-60E keypads. The keypads are also equipped with both jacks and terminals.

The following terminals are on the bottom side of the main board:

- TMP** a pair of terminals to connect the tamper switch of an external device (for example: a wire operated outdoor siren, OS-300). In normal use, these terminals should be connected together via a 2k2 resistor. Triggering of this loop has the same effect as control panel tampering (a change of  $\pm 30\%$  or more of the End Of Line resistor will trigger the input).
- PGX** is an output (transistor switching to GND, max. 12V, 100mA). The function of this output is determined by the setting in the programming mode (see 12.5). The control panel also wirelessly transmits the PGX signal and unit UC-216 or UC-222 can be used as a remote output of this signal.
- PGY** is an output (transistor switching to GND, max. 12V, 100mA). The function of this output is determined by the setting in the programming mode (see 12.5). The control panel also wirelessly transmits the PGY signal and unit UC-216 can be used as a remote output of this signal.
- C** is a common contact of the alarm output relay, max. load 60V / 1A. The relay is turned on during any alarm of the control panel.
- NC** is a normally closed contact of the alarm output relay.
- NO** is a normally open contact of the alarm output relay.
- GND** is a common ground terminal of the power output (-). This terminal is also available on 65H modules.
- SIR** is an external siren output. In the normal mode it has the +U terminal voltage. In the alarm mode it has a GND terminal potential. Connect an ordinary external siren to +U and SIR terminals (max. load 0,7 A). A back up siren charging input should be connected to the GND and the SIR terminals (during an alarm, the charging will temporarily halt). The siren can also be used for sounding arming and disarming chirps and as an audible indicator while in the testing mode.
- +U** is a back up power output for external items (detectors etc.). The max. permanent current is 0.7 or 1.2 A for max. 15 min (not more than one cycle per hour). This output is fused and supervised by the control panel. If it is overloaded, a control panel failure will be indicated (fault C). The multiple +U terminals are also available on the JA-65H hard-wire modules for easier wiring. All +U terminals are connected in parallel to the +U terminal of the main board.

## 7. The JA-65H hard wired input module terminals

Up to two 65H modules can be used in the control panel. The module with its cable connected directly to the main board provides zone inputs 1 to 8. If the second module is installed it will provide zone inputs 9 to 16. The 65H module has the following terminals:

- 1 to 8** zone inputs – Normally, detector outputs are wired here: see examples of wiring in diagram. For each input it is possible to program its method of triggering: Normally Closed loop, balanced loop (10k) or double balanced loop (2x 10k) and the type of reaction of the system (see section 12).
- COM** Four common terminals to close (balance) the input loops
- GND** ground (negative pole) of the power supplier
- +U** backup power output for external devices (detectors etc.), max. total consumption form all +U terminals in the control panel can be 0,7 A.

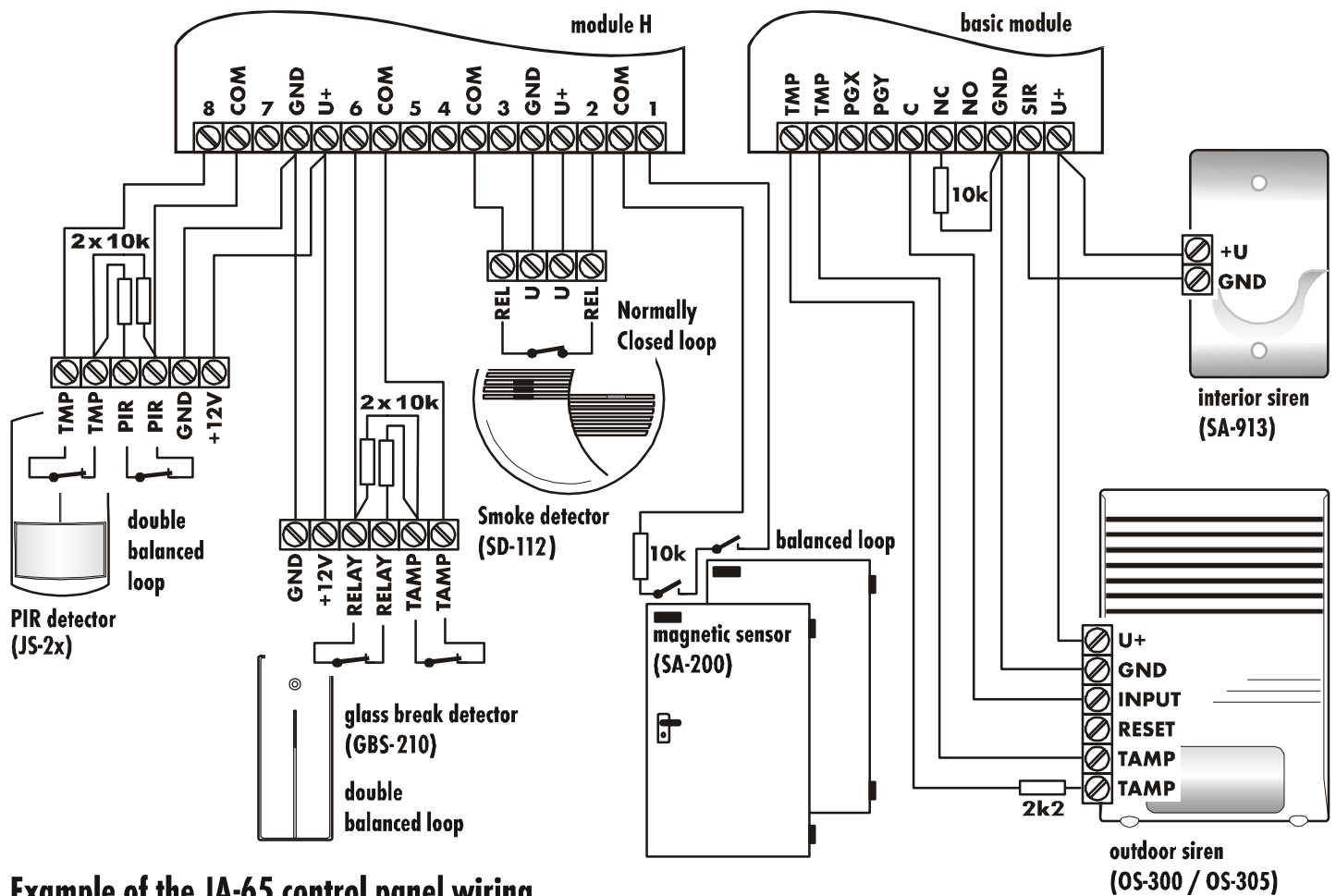

**Example of the JA-65 control panel wiring**

## 8. Wiring of the JA-60 keypad(s)

The system can be programmed and operated by JA-60E keypad(s). As a maximum, 5 keypads can be wired to the control panel. The keypads can either be wired by cables equipped with modular jacks to connectors K4 and K5 or by standard cables to terminals 1,2,3 & 4 on the main control panel board. The same numbered terminals (pins in the connectors) must be linked together. It is possible to combine arbitrary wiring with modular connectors and ordinary cables - see diagram.

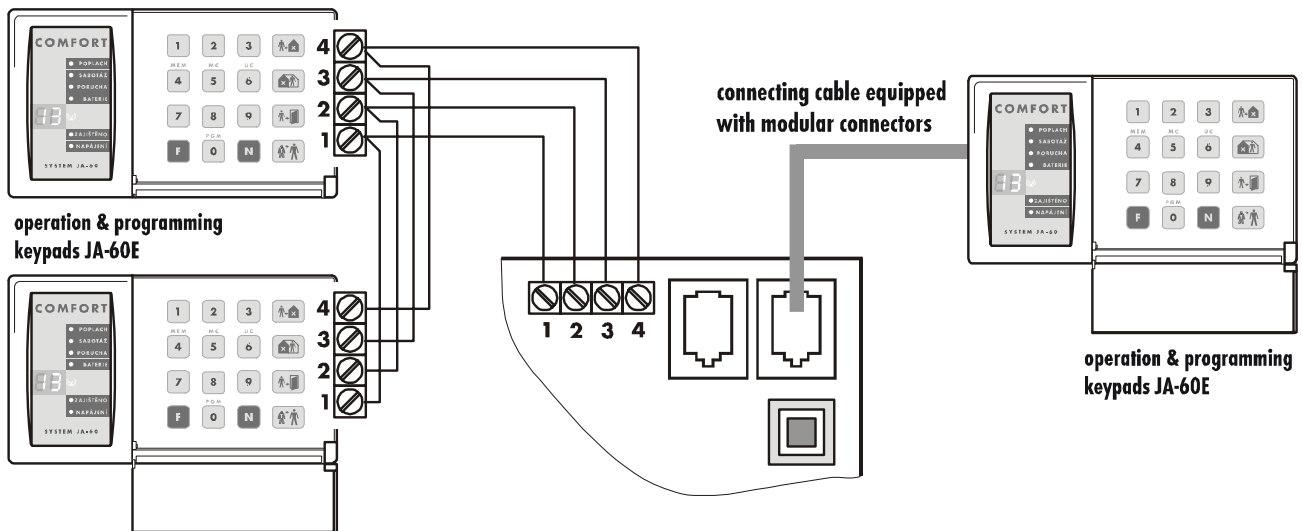

When a control panel has a JA-65R radio communicating module installed, it can also be operated and programmed via JA-60F wireless keypad(s) asunder this situation, a minimum of one JA-60E keypad should be connected to the control panel. With a 65R module, the system can also be operated by remote controls RC-11, RC-22 & RC-60, as well as by a JA-60D wireless keypad. The control panel can have up to 8 wireless controllers.

It is also possible to operate and program the JA-65 system via a connected PC with SW ComLink. The PC can be connected locally with a PC-60A interface cable or remotely, using a JA-60U modem (see section 19 and 20).

## 9. Installation of wireless items

If the control panel is equipped with a JA-65R module, it can work with all types of JA-60 wireless items and wireless UC output modules (see brief overview of items in section 25.1).

- **Detectors** - one wireless JA-60 detector can be enrolled to each control panel zone (i.e. up to 16 detector)
- **Keypads and remote controls** - up to 8 wireless controllers can be enrolled to the control panel (JA-60F and JA-60D keypads, RC-11 and RC-22 remote controls)
- **JA-60A Wireless siren** - only one can be enrolled to a control panel – position A (next JA-60A can be enrolled to detectors positions)
- **wireless output modules UC-216 and UC-222** have relays, which copy the status of the control panel's programmable outputs PgX and Pg Y. An unlimited number of the UC modules can be used with each system.

Follow the particular wireless item manual when installing. After you install the item to desired location, leave it unpowered and without its cover. The method of enrollment is described in section 12.1.

## 10. Back up battery installation

there is a space for size 12V, 7Ah battery. According to the desired backup period a 12V back up battery from 1.3Ah to 45Ah can be used instead. A battery larger than 7Ah must be installed in an external case and the case must be equipped with tamper protection.

The control panel recharges and checks the condition of the back up battery. If the system is powered from the battery for a long time and the battery is nearly discharged, the control panel will first trigger a technical alarm and it will then disconnect the battery to prevent damage. After the main power is on again, the battery will be re-connected and will automatically re-charge.

- insert the battery into the control panel
- connect the battery cables (red +, black -)

**Warning - do not make any short connection of the battery terminals!**

For battery back up time calculation use the following stand-by consumption rates:

module JA-65R	20mA
module JA-65X	12mA
module JA-65H	15mA
main b. JA-65K	10mA
keypad JA-60E	25mA

## 11. First powering of the control panel

- Check that all cables are connected correctly
- Switch on the AC power

- The keypad will display a "P", confirming that the system is in the programming mode (for system setting, enrollment of wireless items and for testing).





**Note:** if „P“ is not displayed, the control panel is not in the factory default setting. Perform a Factory default reset. (See section 17).

## 12. Control panel programming

Functions of the system can be customized. The most convenient programming method is via a connected PC using the Comlink software (see 19). Programming can also be performed by entering programming sequences from the system keypad while in the programming mode:

- If the control panel is not in the programming mode, open it (entering **F 0 SC** - SC = Service Code, factory default SC=6060) – The programming mode will be indicated by a „P“ on the LED display. This mode can only be entered when the panel is disarmed. In this mode, no alarm can be triggered. Detectors and other accessories can be enrolled, the system parameters can be set up and the system can be tested.
- The parameters of the control panel can be set by entering programming sequences from the keypad. Any unfinished programming sequence can be terminated by pressing the **N** key.
- To exit the programming mode, press the N key** („P“ will turn off). If any fault is indicated when you try to exit the programming mode, the control panel will inform you of the problem (see programming sequence 39x for more details).

### List of control panel programmable parameters

Function	sequence	options	factory d.	note
Enrolling of detectors and controllers	1	1 & 7 scroll, 2 erase pos., 3 controllers, 4 all	-	w. R module only
Hard-wired zone input setting	60 nn xyz	nn– zone n., x– triggering, y– reaction, s- section	all off	w. H module only
Exit / Entrance delay	21x	x = 1 to 9 (x 10sec.)	30sec.	
Alarm duration	22x	x = 1 to 8 (min.), 0=10s, 9=15min	4min.	
Function of PgX output	23x	x = 0 to 8 (0-Chime, 1-Fire, 2-Arm, 3-Panik, 4-Alarm, 5-Door, 6-Home, 7-No AC, 8-Phone	Chime	split system has different setting
Function of PgY output	24x	x = 0 to 8 (0-Chime, 1-Fire, 2-Arm, 3-Panik, 4-Alarm, 5-Door, 6-Home, 7-No AC, 8-Phone	Arm	split system has different setting
Voice m. & tel. Numbers editable in the user mode	25x	251 = YES 250 = NO	NO	w. X module only
Radio signal jamming regular testing	26x	261 = YES 260 = NO	NO	w. R module only
Regular communication check enabled	27x	271 = YES 270 = NO	NE	w. R module only
RESET enabled	28x	281 = YES 280 = NO	YES	
Subsystem arming enrollment	290	will enroll to sub-control panel as wireless controller		w. R module only
Control panel enrollment to a UC-2xx, subsystem,...	299	will send enrolling signal		w. R module only
No code requested (effects  ,  ,  , F4, F8 & F9)	30x	301 = YES 300 = NO	YES	
Partial (Home) arming enabled (  )	31x	311 = YES 310 = NO	YES	
Siren alarm enabled	32x	321 = YES 320 = NO	YES	
Exit delay audible indication enabled	33x	331 = YES 330 = NO	YES	
Partial arming exit delay audible indication	34x	341 = YES 340 = NO	NO	
Entrance delay audible indication enabled	35x	351 = YES 350 = NO	YES	
Arming & disarming chirp sounds enabled	36x	361 = YES 360 = NO	NO	
Siren in Disarm & Partial arming enabled	37x	371 = YES 370 = NO	YES	
Wireless siren alarm enabled	38x	381 = YES 380 = NO	YES	w. R module only
Indication of system problems when arming	39x	391 = YES 390 = NO	NO	
Split control panel (A, B & C sections)	690x	6901 = YES 6900 = NO	NO	
Only first source of alarm is recorded	691x	6901 = YES 6910 = NO	NO	
Alarm triggered by opened zone when arming	692x	6921 = YES 6920 = NO	NO	only if 391
Addressing of wireless controllers to sections	63 nns	nn– controller n., s- section	all A	split & R module
Automatic arming/disarming setting	64nahhmm	n- 0-9, a-action #, hh-hours, mm-min.	all off	split & partial arming see 12.21
New Service Code setting	5 nSC nSC	nSC = new Service Code	6060	enter code twice
Real time and date setting	4 hh mm DD MM RR	00 00 01 01 00		
User Mode entering	6999	Switching to the User mode	-	

If the control panel has a 65R module, as a maximum 16 wireless detectors and 8 controllers (remote controls & keypads) can be enrolled to the control panel. A wireless siren and an additional JA-60 or JA-65 control panel (a subsystem) can be enrolled as well.

- **press key 1** (while „P“ is displayed) to enter the enrolling mode. The control panel will display the next free position to enroll a detector.
- **Use key 1 and 6 to scroll** (up and down) all control panel wireless positions – 1 to 16 (detectors) – c1 to c8 (controllers & keypads) – A (wireless siren) – J (sub control panel JA-6x). The display shows the position number while the Battery LED indicates if the position is occupied.
- **Detectors and keypads** are automatically enrolled when their power is switched on (batteries are installed). A remote control is enrolled only after both of its buttons are simultaneously pressed and held for 3 seconds. A subsystem control panel will enroll after sequence 299 is entered while it is in its programming mode. The system will not allow enrollment of an item into a non-corresponding position (a detector can not be enrolled into a controller position etc.).
- **Control panel confirms enrollment** with a „beep“ (press F to select a louder “beep” sound). The LED display will show the number of the enrolled item for 2 seconds and then it will display the number of the next free position.
- **To change the position** of an enrolled item is simple. **Enroll it to the new selected position** (the item will „move“). If you enroll an item to an occupied position, the former item will be deleted and only the new enrollment is valid. Only one item (detector, controller etc.) can be stored to each position.
- **Erase an enrolled item** the following way: in the enrolling mode select the corresponding position and then press and hold key 2 for two seconds. The item will be erased (confirmed with a long beep). If you press and hold key 3, all enrolled controllers (remote controls and keypads) will be erased. Pressing and holding key 4 will erase all enrolled items (detectors, controllers, siren and the sub system).
- **The JA-60A wireless siren will generate an enrollment signal** when its power is switched on (it will enroll to position A). If you need to enroll a siren which is already powered and it is not possible to easily switch off its power, you can enroll it the following way: enter the enrolling mode and then enter the 6 digit siren production code (printed in the siren’s manual). The control panel will “request” the siren to send its enrollment signal. The siren will send the signal only if it has no current communication with any other control panel (This protects you from enrolling your neighbor’s siren). Enrollment is completed about five seconds after the code is entered.
- **By pressing the button 8 in the enrolment mode the communication quality of the items can be checked** (LED indicator “battery” will start flashing). After receiving signal from the item the level of the signal is shown on the display from 0 to 10 (corresponding to 0-100% in the ComLink software). In this mode it is also possible to adjust level of audible indications by pressing the button F and scroll positions of the enrolled items by pressing buttons 1 and 7. Button N exits checking mode.
- **To exit the enrolling mode** press the **N** key

**Note:** *If you do not use JA-60E in your installation, you can enter the learning mode in a different way. Shorten the RESET pins No.K11. This way the JA-60F keypad will be enrolled to the system. You can remove the jumper now.*

**Note:** *if an item was not enrolled after its batteries were installed, it is because the control panel recognized its radio signal as a weak one. Items are only enrolled if their radio signal has a level which guarantees reliable communication. Check the detector’s batteries and try to enroll the problematic sensor once more. If it is not accepted by the control panel, you should change the location of the item. All items should be located 1 m or more from the control panel.*

## 12.2. Hard-wired zone input setting

sequence: **60 nn xys**

If there is a 65H module in the control panel, wire operated detectors can be connected to the control panel. Setting of the zone inputs is possible by entering:

### 60 nn xys

where: **nn** = zone number: 01 to 16

**x** = input triggering: 0 = off, 1 = Normally Closed, 2 = balanced loop (EOL resistor 10 kΩ), 3 = double balanced loop (EOL resistors 2x10 kΩ)

**y** = reaction: 0 = Instant, 1 = Delayed, 2 = Fire, 3 = Panic, 4 = Tamper, 5 = Next delayed, 6 = control

**s** = address to section, 1 = A, 2 = B, 3 = C (shared common section, which is armed only if both A and B sections are armed). If the control panel is not split, select s=1; if you select s=2 then this zone will be automatically bypassed within partial arming. For details about splitting see section 12.22.

#### Notes:

- If you will not use a particular input, switch it off with x = 0
- Next delayed input (y=5) provides entrance delay only if in the moment of its triggering the entrance delay has been in progress (activated before by any delayed input). If no delayed input is triggered before next delayed, the triggering will cause instant alarm.
- Addressing of inputs to section C when the control panel is not split has the same effect as addressing to B section (i.e. automatic bypass while partial arming is used).
- If y=6 is programmed, then each triggering of this input changes arming status (arm – disarm – arm...) of the entire system or just the corresponding section if the system is split.

**Example:** to set zone 2 input as a balanced loop with an instant reaction, addressed to A section, enter: 60 02 201

**Factory default setting:** all hard-wired inputs are switched off.

## 12.3. Exit / Entrance delay

sequence: **2 1 x**

To change the duration of the exit and entrance delay (both of them) enter **21x** (where **x** represents time in seconds x10). The delay can be selected from 10 to 90 seconds.

**Example:** to select an Exit and Entrance delay duration of 20 seconds, enter 212

**Factory default setting:** 30 seconds

## 12.4. Alarm duration

sequence: **2 2 x**

The alarm duration can be selected from 1 to 8 minutes (or 10 seconds or 15 minutes) entering **22x** (where **x** represents time in minutes, for x=0 the duration will be 10 seconds, for x=9 the duration will be 15 minutes).

**Example:** to select an alarm duration of 5 minutes, enter 225

**Factory default setting:** 4 minutes

## 12.5. PgX and PgY output functions

sequences: **2 3 x & 2 4 x**

The control panel outputs PgX and PgY can have different functions, depending on parameter **x** in the corresponding sequence:

**2 3 x** – determines triggering of **PgX**

**2 4 x** – determines triggering of **PgY**

where **x** represents the following functions (non split system):

- 0 Chime** – triggered during the entrance delay (pre-alarm output)
- 1 Fire** – triggered by a fire alarm (by a smoke or a gas detector)
- 2 Arm** – activated when the control panel is armed (complete & partial arming)
- 3 Panic** – activated when a silent panic alarm is triggered
- 4 Alarm** – triggered by any audible alarm (except panic alarm)
- 5 Door** – activated for 5sec. after  (F3) entering (electric door lock opening)
- 6 Home** – activated when the control panel is partially armed (Home arming)
- 7 No AC** – triggered by an AC power failure
- 8 Phone/F8** – output can be operated **remotely by phone** or by SMS (if this feature is supported by installed communicator) or locally **from the keypad** by F81 (ON) and F80 (OFF). If a code is requested to operate the system then the F8x instruction should be followed by a valid user code.

If the system is split:

x	23x (PgX)	24x (PgY)
0	Alarm A	Alarm A
1	Alarm B	Alarm B
2	Chime A	Chime A
3	Chime B	Chime B
4	Arm A	Arm B
5	Door A	Door B
6	Panic A	Panic B
7	FIRE	NoAC
8	Phone	Phone

**Example:** the PgX will work as a Panic output when 233 is entered, PgY as Door output when 245 is entered.

**Factory default setting:** PgX=Chime, PgY=Arm

**Note:** the control panel also wirelessly transmits the PgX and PgY signals. Wireless output modules UC-216 and UC-222 can be used to receive the signals (see 25.1.). The function of the UC module output relays is determined by the 23x and 24x setting.

## **12.6. Recorded message and phone number editing in the user mode** *sequence: 2 5 x*

The **User mode**, which is accessible with F 0 “Master Code”, is for bypass setting, system testing and battery replacement. This setting enables the user to change the voice message and telephone numbers of the built in dialer. If the changes are enabled, then programming sequences for number programming, voice message recording and dialer testing are accessible in the **User mode**. These settings have effect only when the control panel has a 65X communicator module.

options:

**2 5 1** changes **enabled**

**2 5 0** changes **disabled** (no dialer programming in the **User mode**)

**Factory default setting:** changes disabled

## **12.7. Radio signal jamming testing** *sequence: 2 6 x*

When this function is enabled, the control panel will indicate trouble if the working band is jammed for more than 30 seconds. Jamming will trigger an alarm when the control panel is armed. Do not enable this testing, if the control panel does not have a 65R radio module.

options:

**2 6 1** testing **enabled**

**2 6 0** testing **disabled**

**Factory default setting:** disabled

***Note:** in some locations the system can be repeatedly jammed for some period of time (near radar, TV or radio station etc.). In these cases the control panel can work without any problems because all important data is repeated, but the jamming test should not be enabled. The level of the signals and interference can be observed using the Comlink software (see 19.)*

## **12.8. Regular communication checking** *sequence: 2 7 x*

The control panel will check communication regularly with all enrolled items (detectors, keypads, siren etc.) when this function is enabled. If communication is lost with any item, the control panel will indicate the fault of this item (when armed it will also trigger an alarm). Do not enable this checking, if the control panel does not have the 65R radio module.

options:

**2 7 1** checking **enabled**

**2 7 0** checking **disabled**

**Factory default setting:** checking disabled

***Note:** in some locations with a strong radio interference (near radar, TV or radio station etc.) the communication can be jammed periodically. The control panel can detect such a strong interference as a temporary loss of communication with an item. Even in this case, the system is usually able to work without any problems, because all important data is repeated, but the communication check should not be used.*

## **12.9. Reset enabled** *sequence: 2 8 x*

The factory default reset (see 17.) can be disabled. This way no unauthorized future programming of the control panel will be possible.

options:

**2 8 1** reset **enabled**

**2 8 0** reset **disabled**

**Factory default setting:** reset enabled

***Note:** if the Master or Service code is forgotten when the reset is disabled, the reset of the control panel will be possible only by the manufacturer.*

## 12.10. Controlling of a subsystem

sequence: 2 9 0

A wireless master control panel receives event signals (alarms, tampering, faults, low battery) from a JA-6x subsystem if enrolled - see 12.1 and 12.11. This will cause the same kind of event on the master control panel and **J** will be indicated as the source of the event on the keypad.

The master and slave control panels can be either armed and disarmed as two independent systems or the slave system can follow the arming and disarming of the master. If the master should rule arming of the slave subsystem, make the following settings:

- enroll a subsystem to the master's **J** position,
- place the master panel into the programming mode (P is indicated),
- enter the enrolling mode in the sub-control panel (pressing key 1 while in the programming mode)
- enter 290 on the master control panel – this way the master will be enrolled to the slave sub-control panel as a wireless controller (to the first free position of c1 to c8)
- turn both systems to standby mode and check that the subsystem will be armed (in 2 seconds) after arming of the master control panel. Check the same for disarming

### Notes:

- Master control panel generates wireless commands Arm and Disarm the same way as a remote control RC-11. The control panel transmits these commands only if it has a subsystem enrolled in its position J.
- The Arm command is generated when the master control panel is completely armed and also at the end of an alarm while the system remains completely armed (automatic alarm timeout). The Disarm command is generated when the master control panel is disarmed, when it is partly armed (home arming or one section arming if it is split) and also in the end of an alarm while the system is disarmed (manual termination of the alarm).
- The subsystem can also be operated by its other controllers (remote controls, keypads) if there are any. For better understanding you can simply imagine, that the master control panel is just another remote control.

**Controlling** of the subsystem by the master control panel **can be disabled** by erasing the corresponding cN position in the sub-control panel. For example if the master control panel was enrolled to position c3, scroll to this position in the enrolling mode and holding key 2 will erase the master control panel as a controller.

## 12.11. Enrollment of the control panel to a UC-2xx or to a master control panel sequence: 2 9 9



The control panel can send wireless data to output modules UC-216, UC-222 and UC-260 (see section 24.). It can also work as a subsystem of another JA-65 or JA-60 control panel.

Enter the enrolling mode of the **UC receiving device** and then enter **299** and the control panel will transmit the enrollment signal.

If you want to enroll a **subsystem** to your control panel, enter the enrolling mode on the MASTER control panel (see 12.1.) and then enter sequence 299 in the programming mode of the sub control panel.

If the system is split the sub control panel enrolls to the common shared section.

## 12.12 No code requested for , (F1, F2, F3), F4, F8 & F9 sequence: 3 0 x

If this parameter is enabled no code is requested for functions F1, F2, F3, F4, F8 and F9 (or the , ,  keys on the keypad). When this parameter is disabled these functions (keys) can be used only when followed by a code (Master or User) – see the following table:

**Factory default setting:** no code requested

**Note:** this feature is also selectable on the JA-60D wireless keypad and it is independent from the control panel setting.

function / setting	300	301
arming	„code“	F 1
partial arming	F 2 „code“	F 2
door opening	F 3 „code“	F 3
memory reading	F 4 „code“	F 4
Appliance control	F 8 „code“ 0	F 80
	F 8 „code“ 1	F 81
message listening	F 9 „code“	F 9

„code“ = Master or User

## 12.13. Partial (Home) arming with (F2) (non split control panel) sequence: 3 1 x

In partial arming, the control panel reacts only to detectors addressed to section A (see 12.2 and 12.23) and it ignores the triggering of detectors in section B or C (except smoke and gas detectors). Partial arming can be disabled with this sequence.

options:

**3 1 1** partial arming **enabled**

**3 1 0** partial arming **disabled**

**Factory default setting:** partial arming enabled

## **12.14. Hard wired siren alarm enabled**

*sequence: 3 2 x*

The SIR siren output is activated when any alarm is triggered (except silent Panic alarm). The siren indication can be disabled with this parameter.

options:

- 3 2 1** siren **enabled**
- 3 2 0** siren **disabled**

**Factory default setting:** siren enabled

## **12.15. Exit delay audible indication**

*sequence: 3 3 x*

The exit delay can be indicated by the „beeping“ of the keypad (for the last five seconds, the beeping is faster). The audible indication can be disabled with this setting.

options:

- 3 3 1** indication **enabled**
- 3 3 0** indication **disabled**

**Factory default setting:** indication enabled

## **12.16. Partial arming exit delay audible indication**

*sequence: 3 4 x*

Partial arming with  (F2) provides an exit delay for delayed reaction detectors in section A. The exit delay for partial arming can be indicated by the „beeping“ of the keypad (for the last five seconds the beeping is faster).

options:

- 3 4 1** indication **enabled**
- 3 4 0** indication **disabled**

**Factory default setting:** indication disabled

**Note:** when this indication is disabled, the confirmation of partial arming and disarming will automatically be silent, regardless of the 36x setting.

## **12.17. Entrance delay audible indication**

*sequence: 3 5 x*

The entrance delay can be indicated by a rapid „beeping“ of the keypad. This indication can be disabled with this setting.

options:

- 3 5 1** indication **enabled**
- 3 5 0** indication **disabled**

**Factory default setting:** indication enabled

## **12.18. Arming and disarming chirps with hard wired siren**

*sequence: 3 6 x*

The control panel can confirm on the SIR output arming (1 chirp), disarming (2 chirps), disarming with information in the memory (3 chirps), bypass or not ready component when arming (4 chirps). This parameter sets chirps on.

options:

- 3 6 1** siren chirps **enabled**
- 3 6 0** siren chirps **disabled**

**Factory default setting:** siren chirps disabled

**Note:** setting of chirp sounds is valid even if the siren is disabled for alarms with parameter 320. Partial arming is always silent, if sequence 340 is selected. Chirp sounds can also be generated with the JA-60A wireless siren (self-contained setting in the wireless siren).

## **12.19. Siren alarm in Disarm & Partial arming**

*sequence: 3 7 x*

The SIR output can be disabled for alarms during the Disarm & Partial arming of the control panel (while somebody is indoors). If the siren output is completely disabled for alarms with parameter 320, this setting has no effect.

options:

- 3 7 1** alarm in disarm & partial arming **enabled**
- 3 7 0** alarm in disarm & partial arming **disabled**

**Factory default setting:** enabled

## **12.20. Wireless siren alarm**

*sequence: 3 8 x*

The wireless siren alarm function can be disabled with this parameter. This setting will have no influence on the outdoor wireless siren chirp sound function if enabled in the siren. This setting has effect only when the control panel is equipped with a 65R module:

options:

**3 8 1** siren **enabled**

**3 8 0** siren **disabled**

**Factory default setting:** siren enabled

## **12.21. Indication of system problems when arming**

*sequence: 3 9 x*

The system regularly checks the conditions of all items (detectors, keypads etc.). This setting ensures that the user will be warned with 4 rapid beeps after arming, if any component of the system is not ready for arming. Cause of the problem (for example permanently triggered detector, lost communication etc.) will remain displayed on the keypad. If the user ignores this warning, the system will arm after the exit delay, then an alarm will be triggered and finally the problematic item will be bypassed for this arming period. After disarming in such a mode, three beeps will be generated as well.

When the indication is not selected, the problematic item will be bypassed when arming with neither warning nor alarm.

*If a permanently activated detector is deactivated during arming (for example your main door is not closed), the bypass of this detector will be canceled automatically and the detector will be ready to trigger an alarm after it is activated (if you close the door after the system is armed).*

options:

**3 9 1** warning **enabled**

**3 9 0** warning **disabled**

**Factory default setting:** warning disabled

*Note: if this indication is enabled, the problems will also be indicated if there are any when leaving the programming or user mode.*

## **12.22. Control panel splitting**

*sequence: 690 x*

The control panel can be split in to 2 independent sections A and B, with a shared common area C. This way the system can be operated by two independent user groups. In fact the system in this mode works like two independent systems. If the system is split to the sections with this setting, it is possible to address detectors (both wireless and wired), user codes and remote controls to the above sections (see 12.2., 12.23 and 12.24.).

options:

**6 9 0 0** **no splitting** (partial arming available in this mode)

**6 9 0 1** **splitting to sections A, B and common C** (C is armed only when both A and B are armed)

**Factory default setting:** no splitting

## **12.23. Only first source of alarm is recorded**

*sequence: 691 x*

When any item triggers the alarm 4 times in a row the system will bypass it until any other events occurs. But it is possible to set the limit at the incoming events so only the very first event during the entire alarm will be recorded. This function is useful especially if the system contains a GSM communicator in order to decrease quantity of the SMS messages. This setting is valid for all kinds of the alarm.

Options:

**6 9 1 0** **All sources** of alarm are recorded

**6 9 1 1** **Only first source** of alarm is recorded

**Factory default setting:** **All sources** of alarm are recorded

## **12.24. Alarm triggered by opened zone when arming**

*sequence: 692 x*

If the "indication of system problems when arming" (see 10.21) is enabled, it is also possible to test the status of the detectors after expiring the exit delay. If any item is activated then in case of instant zone the alarm will be triggered immediately, in case of delay zone the entry delay will start.

Options:

**6 9 2 0** **test disable**

**6 9 2 1** **test enable**

**Factory default setting:** test disabled

## 12.25. Addressing of wireless detectors to sections

sequence: 61 nns

If the control panel is split (see 12.21.) and is equipped with a 65R module, the wireless detectors can be addressed to sections by entering:

### 61 nns

where: **nn** = wireless detector zone number: from 01 to 16

**s** = section: 1 = A, 2 = B, 3 = C (common section - it is armed only when both A and B are armed). If the control panel is not split, and s=2 (or s=3) is selected, this detector will be bypassed while partial arming.

**Example:** to address wireless detector zone number 3 to section A enter: 61 031

**Factory default setting:** detectors 1 - 10 are addressed to A, detectors 11 - 16 are addressed to B

## 12.26. Addressing of the user codes to sections

sequence: 62 nns

If the control panel is split (see 12.21.), the user codes can be addressed to sections A or B by entering:

### 62 nns

where: **nn** = user code number: from 01 to 14

**s** = section: 1 = A, 2 = B

#### Notes:

- If the control panel is not split, this setting has no effect.
- Master code (MC) can not be addressed. If the system is split, the use of MC will arm all sections if no section is armed or it will disarm all sections if any is armed. If you want to operate only section A with master code, enter F1 MC and F2 MC for section B.

**Example:** to address user code number 4 to section A enter: 62 04 1

**Factory default setting:** all user codes (01 - 14) are addressed to section A

## 12.27. Addressing of wireless controllers to sections

sequence: 63 nns

If the control panel is split (see 12.21.) and is equipped with a 65R module, the wireless controllers (RC-11, RC-22 and JA-60D) can be addressed to A or B section by entering:

### 63 nns

where: **nn** = number of the enrolled controller from 01 to 08 (c1 to c8)

**s** = section: 1 = A, 2 = B

#### Notes:

- If the control panel is not split, this setting has no effect
- For the JA-60F keypad this setting has no effect (its user codes are determined by 62nns setting)

**Example:** to address controller number 5 to section A enter: 63 051

**Factory default setting:** all wireless controllers are addressed to section A

## 12.28. Automatic arming / disarming setting

sequence: 64 nahhmm

The control panel can automatically arm and disarm for a requested period of a day. Up to ten instructions (time & action) can be programmed in the period of one day by entering:

### 64 nahhmm

where: **n** = instruction number from 0 to 9

**a** = action (see the actions' table)

**hh** = hours (from 00 to 23)

**mm** = minutes (from 00 to 59)

actions' table

a	no splitting	split system
0	no action	no action
1	arm all	arm all
2	disarm	disarm all
3	partial arming	arm A
4	partial arming	arm B
5	disarm	disarm A
6	disarm	disarm B

#### Notes:

- If any automatic action is selected, it will be performed everyday in the programmed time, following the internal control panel clock (see 12.27.).
- The automatic arming and disarming can be overridden manually anytime (by an user code or a remote control)
- If the control panel is in the requested arming mode before the action time, performance of the programmed action will not change the arming

**Example:** to program an automatic complete arming of the system at 21:15 everyday enter: 64 0 1 21 15

**Factory default setting:** all instructions are set for no action

## 12.29. New service code setting

sequence: **5 nSC nSC**

The Service Code can be used to enter the programming mode. A new Service Code must be entered twice in the sequence to avoid an error.

To change the code enter:

**5 nSC nSC**

where nSC is your new Service Code (four digits)

**Example:** to change service code to 1276 enter: 5 1276 1276

**Factory default setting:** service code is 6060

## 12.30. User Mode entering

Sequence: **6 9 9 9**

This sequence is used to switch from the Service Mode to the User Mode, where you can set zones' bypass (see User's manual). You can exit the User Mode by pressing the "N" button. The bypassed zones will remain active after the leaving the User Mode.

## 12.31. Real time and date setting

sequence: **4 hh mm dd MM YY**

The control panel has a built in real time clock. All events are stored to the event memory including the time of the event. The clock should be set after the installation is completed. Time Setting:

**4 hh mm dd MM YY**

where **hh = hours** (24 hr. cycle)

**mm = minutes**

**dd = day**

**MM = month**

**RR = year**

**Example:** on Jun. 30 2005 at 17:15 enter: 4 17 15 30 06 05

After the control panel is powered, its internal clock's default setting is: 00 00 01 01 00

**Note:** detail control panel event history can be viewed with a connected PC using Comlink software.

## 13. System testing

For testing, the control panel should be in the programming mode - "P" indicated on the keypad (see part 12. how to enter programming). No alarm can be triggered in the programming mode and any triggering of a detector (wireless or wired) will make a beep (press F to select for a loud beep by siren) and the LED display will show for a while which zone was triggered. An enrolled wireless controller or siren signal receiving will be similarly indicated.

- **Some detectors (JA-60P, JA-60N, JA-60B etc.)** have an extra testing mode, which is usually activated for 5 minutes after the detector's cover is attached (see manuals of the particular detectors). If the detector is in testing mode, it will indicate triggering locally, and it will also indicate the triggering on the control panel keypad. Note, that the JA-60P motion detector in normal mode (after 5 minutes testing mode) is ready to send information about next triggering 5 minutes after the previous triggering (this period can be shortened to 1 minute - see setting of the JA-60P detector).
- **Triggering of a detector wired** to the H module is indicated at the control panel keypad for about 2 seconds after the triggering. It means, that if a detector is permanently triggered for a longer period, it will not be indicated. If a double balanced input loop (2x 4k7) is used, then the control panel distinguishes triggering of the detector from its tampering.
- **The best way of testing** is via a connected PC using the Comlink software (see section 19). In the service events window you will get a chronological record of all performed tests, including zones setting, quality of communication etc.

**The system can also be tested by a user** in the user mode (confirmed by a "U"). The user mode is accessible with the Master code. To open the user mode enter F 0 MC (= Master Code) when the control panel is disarmed.

## 14. Voice & Pager messages setting

A control panel equipped with the X module can automatically send 2 voice and 5 short text messages (or dial a Pager) . The most convenient programming of the dialer is via a connected PC using the Comlink software (see section 19). Programming can also be performed manually from the keypad:

- Enter the programming mode (entering **F 0 SC** - SC = Service Code, factory default SC=6060), indicated by a „P“ on the LED display. This can only be done while the panel is disarmed.
- The parameters of the dialer can be set by entering programming sequences from the keypad. Any unfinished programming sequence can be terminated by pressing the **N** key.
- **To exit the programming mode, press the N** key („P“ will turn off). If any fault is indicated when you try to exit the programming mode, the control panel will inform you about the problem (see 12.22.).
- Telephone numbers and the voice message(s) can also be set up in the User Mode when enabled (see section 12.6.)

### List of the voice & Pager programmable parameters

Function	sequence	options	factory d.	note
Dialing method	<b>90x</b>	901 = tone 900 = pulse	tone	valid also for PCO transfer
Triggering of the dialer with a Panic alarm	<b>91x</b>	911 = YES 910 = NO	1	
Triggering of the dialer with an Intruder alarm	<b>92x</b>	921 = YES 920 = NO	1	
Triggering of the dialer with a Fire alarm	<b>93x</b>	931 = YES 930 = NO	1	
Triggering of the dialer with a Tamper alarm	<b>94x</b>	941 = YES 940 = NO	1	
Triggering of the dialer with a Technical alarm	<b>95x</b>	951 = YES 950 = NO	1	
Telephone line checking enabled	<b>99x</b>	991 = YES 990 = NO	NO	
Store telephone numbers for voice message	<b>7xx..x F y</b>	xx...x = tel. number, y = memory 1 to 4, pause = F0	1: 2: 3: 4: 5:	
Pager dialing programming	<b>7x.xF9z..zF5</b>	x..x = provider tel. number z..z = pager number + message		
Erase telephone number	<b>7F0Fy</b>	y = memory 1 to 5, entering <b>7F0F0</b> erases all		
Record voice messages (1 & 2)		mess. 1 enter <b>85</b> then push button on X module and speak (10sec.) mess. 2 enter <b>86</b> then push button on X module and speak (10sec.)		
Dialer testing		<b>89</b>		2 messages - 88 & 89

### 14.1. Telephone number entering

sequence: **7xxx....xxFy**

Store telephone numbers for voice message entering:

**7 xx... xx F y**

where **xx...xx** = telephone number  
**y** = memory number from 1 to 4

A telephone number can have a maximum of 16 digits. A **pause** can be entered with **F0** (pause can not be entered as the first digit).

*Example: to store tel. number 483 123456 to memory no. 2 enter: 7 483 F0 123456 F2*

*Note: enter a pause (F0) after the last digit of a number which is calling a mobile phone. This way the number will be called only once and the dialer will not check the line signals (some mobile phone systems do not generate standard telephone line signals).*

**When activated, the dialer will** disengage all other devices hooked up to the phone line (telephone, fax..). It will then, one by one, call and play the user recorded message, for all programmed numbers. If the dialer makes a successful connection to a programmed number, it will not call that number again. If the number is busy, the dialer will make 3 more attempts to call it.

Empty tel. number memories are skipped. If all memories are empty, the dialer is completely disabled. If the dialer is communicating to the monitoring station, the data is sent to the monitoring station at first.

To delete a telephone number enter:

**7 F0 Fy**

where **y** is a memory number from 1 to 4  
entering **7 F0 F0** will erase all tel. numbers, including the Pager number

Store number to call Pager (to memory number 5) entering:

**7 xx..x F9 zzz....zz F5**

- where **xx...x** = provider prefix
- F9** = separator (it will wait for a provider's signal and will switch to DTMF if not used)
- zzz...zz** = pager number and numeric message and other specific codes (language selectors, end of message etc.) if requested by the Paging provider
- F5** = to store the number to memory no. 5

As a maximum 32 digits can be stored to memory number 5. Special characters can be entered with the following Fx codes:

- pause **F0**
- \* **F7**
- # **F8**

Example: enter 7 0611 F9 1 1234 555 F80 F5 if the provider prefix is 0611, the Pager number 1234 and the message 555. Number 1 after F9 is a language selector, code F80 represents # 0 = end of message.

Note: some Paging providers also offer an option to send the message as an **SMS to the GSM network**. Consult your Paging provider for details if you have trouble sending a message to the Pager.

To delete the Pager number enter:

**7 F0 F5**

If the memory number 5 is empty, no message will be sent to a Pager.

Factory default setting: all memories from 1 to 5 are empty.

### 14.2. Voice message(s) recording

**sequence: 8x**

You can record two different voice messages (10 sec. each). Depending on the setting in section 14.3, a particular message will be sent under different situations. Recording of the messages:

- a) **enter 85** on the keypad
- b) **press and hold push button** on the X module
- c) **speak** towards the module (max. 10 s)
- d) **release the button**, message will be replayed

This results in the recording of message number 1. **To record message 2 enter 86** in step a)

If you prefer sending only one, but longer, message (20 sec.), record message by entering 84 in step a). By programming as described in section 14.3 you can specify which alarms will trigger the sending of a message.

**Notes:**

- Make the messages brief and clear. The dialer repeats the message to each called number for 40 seconds.
- The voice messages are stored in non-volatile memory and can be changed whenever you want to by repeating the above steps.
- The existing messages can be played by momentarily pressing the push button on the X module (or by entering F9 while in stand by mode).

### 14.3. Telephone dialer triggering

**sequences: 9 y x**

With sequences 91x to 95x you can select which alarms will trigger the telephone dialer to call and which ones will not. Enter:

**9 y x**

where

y	Alarm	x	reaction
1	Panic – silent	0	not to call
2	Intruder	1	voice message & Pager code
3	Fire	2	voice message only
4	Tampering	3	Pager code only
5	Technical trouble		

Example: if the dialer should not call when the system is tampered, enter 940

Factory default setting: all alarms will trigger the dialer (it means 911, 921, 931, 941 & 951)

If two different voice messages were recorded (see 14.2.), then parameter x specifies which message will be sent.

x	reaction
0	not to call
1	send message #1 and Pager code
2	send message #2 only
3	Send Pager code only

## 14.4. Dialing method

*sequence: 9 0 x*

Enter:

**9 0 1** for **tone** dialing

**9 0 0** for **pulse** dialing (this option is blocked for some countries)

**Note:** *this dialing method setting is also valid for Monitoring station communications as well as remote PC access*

Factory default: tone dialing

## 14.5. Telephone line checking

*sequence: 9 9 x*

If this function is enabled, the dialer will check regularly if the telephone line is ready to make a phone call. If the line is not ready for more than 15 minutes, the keypad will indicate a telephone line failure (failure L). Not working telephone line or a phone conversation or Internet connection longer than 15 minutes can cause a fault.

options:

**9 9 1** checking **enabled**

**9 9 0** checking **disabled**

**Note:** *this setting is also valid when the dialer is used for Monitoring station communications as well as remote PC access*

**Factory default setting:** checking disabled

## 14.6. Telephone dialer testing

*sequence: 8 9*

Entering **89** and the dialer will call the programmed numbers once. You will hear the telephone line signals from the control panel built in speaker during the test (if the dialer is triggered by an alarm in normal operation, it will call silently). Testing can be terminated with the **N** key.

*If two different voice messages were recorded, then use sequence 88 to test the sending of the first message and 89 to test the sending of the second message.*

## 15. To enable a remote computer to dial in

When the user or installer wants to dial in to the installation from their JA-60U modem equipped computer (see 20.), the following parameters should be programmed in the 65X control panel's telephone dialer.

The most convenient programming of the dialer is via a connected PC using the Comlink software (see 19). Programming can also be performed by entering programming sequences from the system keypad while in the control panel programming mode:

- Enter the programming mode (entering **F 0 SC** - SC = Service Code, factory default SC=6060), indicated by a „P“ on the LED display. This can only be done while the panel is disarmed.
- The programming sequences can be entered from the keypad. Any unfinished sequence can be terminated by the **N** key.
- **To exit the programming mode, press the N key** („P“ will turn off).

### Dialing in parameters

Function	sequence	options	factory d.	note
Incoming call reaction	<b>0 5 x</b>	0=disabled, 1= second call, 2-6 = after ring No. 2 - No.6	disabled	
Remote access code (8 digits)	<b>0 7 xxxxxxxx</b>	any 8 digits code	00000000	

### 15.1. Reaction to an incoming call

**sequence: 05**

This sequence sets how the communicator will react to incoming calls on the telephone line. This setting is important for access from a remote computer.

#### 0 5 x

x can be **0** - never answer

**1** - answer after second call = after 1 or 2 rings are detected, there must be a pause of 10 - 45 seconds. The dialer will then answer on the very first ring of the second call. This setting can be used to bypass an answering or facsimile machine connected to the same line. This "Second Call" feature is supported by the Comlink software

**2, 3, 4, 5, 6** - answer after 2<sup>nd</sup>, 3<sup>rd</sup>, 4<sup>th</sup>, 5<sup>th</sup> or 6<sup>th</sup> ring

**Notes:** Remote access connection can also be enabled by the alarm system user (regardless of the above setting) by entering code 89 during service or user mode, when a remote call rings. If you use another telephone set on the same telephone line, it should be switched to a tone dial mode.

**Factory setting:** 0 = never answer

### 15.2. Remote access code setting

**sequence: 07**

In order to access the panel from a remote computer, it is necessary to authorize the access with an 8-digit access code. This code is compared with the one programmed in the control panel. If the remote computer tries to access the panel with an other code, the connection will be terminated immediately and a wrong code alarm will triggered on the control panel. Store your access code to the control panels by entering:

#### 0 7 xxxxxxxx

x x . . . . . x - any 8 digits access code

**Factory setting:** 00000000

## 16. Monitoring station communication setting

This part of the manual is intended only for the use of specialists involved in monitoring. We recommend to use a computer equipped with Comlink program for complete setting of the monitoring station communication (see 19). Changes of the setting can also be performed manually using the keypad:

- Enter the programming mode (entering **F 0 SC** - SC = Service Code, factory default SC=6060), indicated by a „P“ on the LED display.
- **To exit the programming mode, press the N key („P“ will turn off).**

### Monitoring station communication parameters

Sequence	Description	Factory default setting															
<b>0 001 xx</b> to <b>0 198 xx</b>	Reporting codes table (see part 18) where: <b>x = 0 – 9, F0 = A<sub>h</sub>, F1 = B<sub>h</sub>, F2 = C<sub>h</sub>, F3 = D<sub>h</sub>, F4 = E<sub>h</sub>, F5 = F<sub>h</sub></b> if <b>00</b> is set, the event is not reported	00	For all events														
<b>0 2 xxxx</b>	Account code (4 digits, for 3/1 and 3/2 formats the structure is 0xxx) <b>x = 0 – 9</b> (hexadecimal codes can be used too - see above)	0000															
<b>0 3 xy</b>	Protocol <b>x</b> : <table style="display: inline-table; vertical-align: top; border: none;"> <tr> <td style="padding-right: 10px;">0 = Ademco Slow</td> <td>5 = Radionics 1400</td> </tr> <tr> <td>1 = Ademco Fast</td> <td>6 = DTMF 2300</td> </tr> <tr> <td>2 = Telexmax</td> <td>7 = Surgard</td> </tr> <tr> <td>3 = Franklin</td> <td>8 = Ademco Express</td> </tr> <tr> <td>4 = Radionics 2300</td> <td>9 = Contact ID</td> </tr> </table> Format <b>y</b> : <table style="display: inline-table; vertical-align: top; border: none;"> <tr> <td>0 = 3/1 (xxx R)</td> </tr> <tr> <td>1 = 3/2 (xxx rc)</td> </tr> <tr> <td>2 = 4/1/1 (xxxx Rn)</td> </tr> <tr> <td>3 = 4/2 (xxxx rc)</td> </tr> </table>	0 = Ademco Slow	5 = Radionics 1400	1 = Ademco Fast	6 = DTMF 2300	2 = Telexmax	7 = Surgard	3 = Franklin	8 = Ademco Express	4 = Radionics 2300	9 = Contact ID	0 = 3/1 (xxx R)	1 = 3/2 (xxx rc)	2 = 4/1/1 (xxxx Rn)	3 = 4/2 (xxxx rc)	90	Contact ID
0 = Ademco Slow	5 = Radionics 1400																
1 = Ademco Fast	6 = DTMF 2300																
2 = Telexmax	7 = Surgard																
3 = Franklin	8 = Ademco Express																
4 = Radionics 2300	9 = Contact ID																
0 = 3/1 (xxx R)																	
1 = 3/2 (xxx rc)																	
2 = 4/1/1 (xxxx Rn)																	
3 = 4/2 (xxxx rc)																	
<b>0 4 x</b>	Re-dialing pause, <b>x = 1 – 9</b> (x 10 min.)	1	10 minutes														
<b>0 6 xx..xFy</b>	Phone numbers <b>xx...x</b> to memory <b>y</b> (1 and 2), pause = F0		erased														
<b>0 9 6060</b>	Communicator reset to factory default settings		-														

**Dialing method** (tone / pulse) and **telephone line checking** has a common setting with the voice & Pager message setting - see part 14.4. and 14.6.

#### Notes:

Some of the protocols are not standardized and some manufacturers of Monitoring Station receivers use different parameters in some of their protocols. Therefore Jablotron cannot guarantee full compatibility with all Monitoring Station receivers.

If the connection with the Monitoring Station is not available, the events are queued in the communicator's memory and are transmitted in one burst as soon as the connection is established. All events are reported to the Monitoring Station in the same order as they happened.

Once communication has started, it can not be interrupted unless the control panel is

switched to the programming or to the user mode. For example, if the user causes a false alarm and then cancels it, both events are sent to Monitoring Station.

Events occurring while the JA-65 control panel is in a programming or user mode are reported to the Monitoring Station after the closing of these modes. (They are stored in the memory and reported together with reporting codes describing the change of operation modes.)

When the dialer is activated, the communication to the monitoring station has the highest priority (voice and Pager messages are sent later with lower priority). A User or Installer can interrupt the digital dialer

communication by entering the User mode or Programming mode. Reset of the control panel has no influence to the digital communicator's settings (it is reported to the Monitoring station as an event).

The RESET of the digital communicator itself (sequence 0 9 6060), the change of the Monitoring Station's telephone numbers, the change of an account number code or the change of a format setting will erase all the reporting codes queued in the communicator's memory. However the events remain stored in the control panel's internal memory.

**Jablotron recommends use of the MS-300 monitoring station with ComGuard SW.**

### 16.1. Reporting code setting

### sequences: 00 and 01

These sequences can be used to program the report codes for all possible events. Depending on the used protocol and format, different amounts of data should be entered. The complete report code programming table is shown in section 18. The setting sequence structure is as follows:

**0 x x x r c**

**xxx** = event number (from 001 to 198)

**rc** = report code (two digits). For 3/1 and 4/1/1 formats only the first digit of the report code is used (R). Codes should be entered in a hexadecimal format, with numbers higher than 9 beginning with the F key: **A<sub>h</sub> = F0 B<sub>h</sub> = F1 C<sub>h</sub> = F2 D<sub>h</sub> = F3 E<sub>h</sub> = F4 F<sub>h</sub> = F5**

If the reporting code 00 is programmed, the event will not be reported to the Monitoring Station.

**Factory setting:** 00 for all events

#### Notes:

- Abbreviation "Rc" is used in the report code programming table for the major events group. Only the first digit of this group of codes is transmitted when formats 3/1 or 4/1/1 are used. Other formats use both digits of the "Rc" and "rc" report codes.
- The Contact ID (CID) is an automatic protocol. If you enter any report code other than zero for a major event (Rc), all events of this type will be transmitted automatically including all details regarding the event source. Internal structure of the CID protocol is shown in the part 18.1. This protocol provides the most in-depth data for the monitoring station and its use is recommended by Jablotron.
- The Surgard protocol has 4/2 structure plus one more digit which is generated automatically (see 16.3.)
- If the control panel is split and only one section is armed, then a partial arming report code is sent. If all sections are armed, a complete arming report code is sent. If the system was completely armed and only one section is disarmed, the disarming report code will be sent and then it will be followed by the partial arming report code.

- The pulse formats are not capable to report zero and numbers above 15. For this reason events in zone 16 or in a subsystem are reported to the Monitoring Station as events in zone 10. This means that from the point of view of the monitoring station zone 10 also covers zone 16 and the subsystem if used. This problem does not exist in the CID protocol.
- If the system is arming while there is a bypass, partial arming will be reported to the CMS (also stored to the internal memory)

## 16.2. Account code setting

**sequence: 02**

This sequence is used for the alarm system identification by a Monitoring Station. The sequence structure is as follows:

**02 x x x x**

**xxxx** – account code ( x are numbers from 0 to 9 or hexadecimals).

When using only three-digit codes (formats 3/1 and 3/2) enter a zero in the first position. The communicator will then ignore it (example - 0123)

**Note:** Changing of the account code erases the internal communicator's memory of non reported events and sends a „Reset“ reporting code (051) to the Monitoring Station. If pulse formats are used, zero is transmitted as **A<sub>h</sub>**

**Factory setting:** 0000

## 16.3 Protocol and Format setting

**sequence: 03**

This sequence is used to select the communication protocol and format. Its structure is as follows:

**03 x y**

**x** - protocol (0 – 9, see table bellow)

**y** - format (0 - 3 see table on right)

Protocols						
x	Name	Hand-shake	Data	Kiss off	Speed	format
0	Ademco Slow (Silent Knight)	1400Hz	1900Hz	1400Hz	10bps	Next table
1	Ademco Fast	1400Hz	1900Hz	1400Hz	14bps	Next table
2	Telexmax	2100Hz	1650Hz	2100Hz	10bps	Next table
3	Franklin	2300Hz	1800Hz	2300Hz	20bps	Next table
4	Radionics 2300	2300Hz	1800Hz	2300Hz	40bps	Next table
5	Radionics 1400	1400Hz	1900Hz	1400Hz	40bps	Next table
6	DTMF 2300	2300Hz	DTMF	2300Hz	DTMF	Next table
7	Surgard*	2300Hz	DTMF	2300Hz	DTMF	4/3
8	Ademco express*	Dual tone	DTMF	1400Hz	DTMF	4ID/2
9	Contact ID*	Dual tone	DTMF	1400Hz	DTMF	CID

\* fixed format, "y" is arbitrary (0 is recommended)

Notes:

1/ Some Monitoring Station receivers do not support all formats.

2/ Logic of the format marking - 4/2 means, that an account code has 4 digits and an event report code has 2 digits.

Changing of a format erases the internal communicator's memory of non reported events and sends a „Reset“ reporting code (051) to the Monitoring Station.

**Factory setting:** 90 (Contact ID)

## 16.4. Re-dialing pause setting

**sequence: 04**

If a dialer is triggered it attempts to make a connection (altering the main and the backup telephone number). If it is not possible to make a connection after 8 attempts, a pause is inserted. After this pause the dialer dials again. If any event triggers the communicator during the pause, the pause ends immediately. The pause length can be set in a following way:

**04 x**

**x** – time multiplied by 10 minutes (from 1 to 9, example 3 = 30 minutes)

**Factory setting:** 1 = 10 min.

Formats			
y	format	reports	structure
0	3/1	Major events only	xxx R
1	3/2	All events	xxx rc
2	4/1/1	Major events with autom. source identification	xxxx Rn
3	4/2	All events	xxxx rc

**xxxx** = account number

**R** = major event code (only first digit counts)

**rc** = detailed event code (two digits)

**n** = source identification (generated automatically)

**Surgard** protocol has structure: **xxxx E rc**, where **E** is a group identifier (generated automatically)

E	Event	Note
1	Fire	
2	Panic	
3	Alarm	General
4	Arming	Incl. Partial
5	Disarming	
6	Failure	Mains failure, RF jamming etc..
8	Report	Enter/Exit service mode ...
9	Restore	End of alarm, panic ...
A	Test	24 hour test

## 16.5. Phone number entering

**sequence: 06**

Monitoring station modem phone numbers can be stored by entering the following sequence:

**0 6 x x .... x F y**

**xx...x** - Monitoring Station phone number (up to 16 digits)  
**y** is 1 for main phone number memory  
2 for back up phone number memory

**Pause** (3 sec.) can be inserted into the telephone number by entering **F0**. It is also possible to insert the \* tone by **F7** or the # tone by **F8** if requested for DTMF dialing.

**Example:** number 02 123456 as main Monitoring Station number is entered with 06 02 F0 123456 F1.

### Phone number erasing

**0 6 F 0 F y**

**y** is 1 to erase the main telephone number  
2 to erase the back up telephone number

**Note:** Changing of a phone number erases the internal communicator's memory of non reported events and sends a „Reset“ reporting code (051) to the Monitoring Station.

**Factory setting:** both numbers are erased

## 16.6. Digital communicator reset

**sequence: 096060**

By entering this sequence the factory default settings of all parameters are restored. All phone numbers, reporting codes, account codes etc. are erased. This reset doesn't effect the voice dialer's settings. The reset sequence is:

**0 9 6060**

**Note:** All communicator settings are normally stored in non-volatile memory and remain unchanged even after switching off the power supply.

## 17. Control panel factory default reset

If you forgot the control panel codes or you have a control panel which is currently not under factory default setting, perform the following procedure:

- disconnect the power unit cable from the K5 connector on the main board of the control panel and wait for 10 sec.
- connect the RESET jumper N. K11 on the main board
- control panel TAMPER must be open
- reconnect the power cable to the K5 connector, "-" will be displayed on the keypad
- within 1 minute disconnect the RESET jumper
- Disconnect the jumper (if you haven't done it before)
- reset is confirmed with "P" (panel is in programming mode)

**Note:** this procedure resets the factory default settings (see part 12.). The Master code will be 1234, Service code 6060 and all user codes, wireless detectors & controllers will be forgotten. All telephone numbers for voice message and Pager dialing will be erased in the 65X communicator. The reset will not erase event memory and information about the reset will be recorded there.

**Warning:** if the Master code is forgotten when reset is disabled (with sequence 280), the control panel reset will be possible only by the manufacturer.

## 18. Monitoring station report code table

A two digit report code **rc** (00 to FFh) can be set for every event. If 00 is programmed as a report code, that event will not be reported.

The major events group is marked by **Rc**. When formats 3/1 or 4/1/1 are used, only 16 of these major events are reported to the Monitoring Station. This makes it necessary to only program the **R** digits. The second digit does not count. Zero can not be used in the pulse protocols.

For Contact ID protocol, program code 11 for major events (**Rc**) which you want to report and the system will generate all details regarding the event automatically including the events source details (see part 18.1).

N.	Event	Code
001	<b>Arming with remote control N.1</b>	<b>Rc</b>
002	Arming with remote control N.2	Rc
003	Arming with remote control N.3	Rc
004	Arming with remote control N.4	Rc
005	Arming with remote control N.5	Rc
006	Arming with remote control N.6	Rc
007	Arming with remote control N.7	Rc
008	Arming with remote control N.8	Rc
009	Arming with master code	Rc
010	Arming with user code N.1	Rc
011	Arming with user code N.2	Rc
012	Arming with user code N.3	Rc
013	Arming with user code N.4	Rc
014	Arming with user code N.5	Rc
015	Arming with user code N.6	Rc
016	Arming with user code N.7	Rc
017	Arming with user code N.8	Rc
018	Arming with user code N.9	Rc
019	Arming with user code N.10	Rc
020	Arming with user code N.11	Rc
021	Arming with user code N.12	Rc
022	Arming with user code N.13	Rc
023	Arming with user code N.14	Rc
024	<b>Partial arming</b>	<b>Rc</b>
025	<b>Quick arming without code</b>	<b>Rc</b>
026	<b>Disarming with remote control N.1</b>	<b>Rc</b>
027	Disarming with remote control N.2	Rc
028	Disarming with remote control N.3	Rc
029	Disarming with remote control N.4	rc
030	Disarming with remote control N.5	rc
031	Disarming with remote control N.6	rc
032	Disarming with remote control N.7	rc
033	Disarming with remote control N.8	rc
034	Disarming with master code	rc
035	Disarming with user code N.1	rc
036	Disarming with user code N.2	rc
037	Disarming with user code N.3	rc
038	Disarming with user code N.4	rc
039	Disarming with user code N.5	rc
040	Disarming with user code N.6	rc
041	Disarming with user code N.7	rc
042	Disarming with user code N.8	rc
043	Disarming with user code N.9	rc
044	Disarming with user code N.10	rc
045	Disarming with user code N.11	rc
046	Disarming with user code N.12	rc
047	Disarming with user code N.13	rc
048	Disarming with user code N.14	rc
049	<b>Entering of the programming mode</b>	<b>Rc</b>
050	<b>Exiting the programming mode</b>	<b>Rc</b>
051	<b>Communicator Reset</b>	<b>Rc</b>
052	<b>Initial AC powering</b>	<b>Rc</b>
053	<b>Alarm after initial AC powering</b>	<b>Rc</b>
054	<b>General battery trouble</b>	<b>Rc</b>
055	<b>General battery trouble end</b>	<b>Rc</b>
056	<b>Control panel battery trouble</b>	<b>Rc</b>
057	<b>Control panel battery trouble end</b>	<b>Rc</b>
058	<b>Zone alarm 1</b>	<b>Rc</b>
059	Zone alarm 2	rc
060	Zone alarm 3	rc
061	Zone alarm 4	rc
062	Zone alarm 5	rc
063	Zone alarm 6	rc
064	Zone alarm 7	rc
065	Zone alarm 8	rc
066	Zone alarm 9	rc
067	Zone alarm 10	rc
068	Zone alarm 11	rc
069	Zone alarm 12	rc
070	Zone alarm 13	rc
071	Zone alarm 14	rc
072	Zone alarm 15	rc
073	Zone alarm 16	rc
074	<b>Wrong access code alarm</b>	<b>Rc</b>
075	<b>Zone tamper 1</b>	<b>Rc</b>
076	Zone tamper 2	rc
077	Zone tamper 3	rc
078	Zone tamper 4	rc
079	Zone tamper 5	rc
080	Zone tamper 6	rc
081	Zone tamper 7	rc
082	Zone tamper 8	rc
083	Zone tamper 9	rc
084	Zone tamper 10	rc
085	Zone tamper 11	rc
086	Zone tamper 12	rc
087	Zone tamper 13	Rc
088	Zone tamper 14	Rc
089	Zone tamper 15	Rc
090	Zone tamper 16	Rc
091	Keypad tamper	Rc
092	Control panel tamper	Rc
093	Siren tamper	Rc
094	<b>Zone fault 1</b>	<b>Rc</b>
095	Zone fault 2	Rc
096	Zone fault 3	Rc
097	Zone fault 4	Rc
098	Zone fault 5	Rc
099	Zone fault 6	Rc
100	Zone fault 7	Rc
101	Zone fault 8	Rc
102	Zone fault 9	Rc
103	Zone fault 10	Rc
104	Zone fault 11	Rc
105	Zone fault 12	Rc
106	Zone fault 13	Rc
107	Zone fault 14	Rc
108	Zone fault 15	Rc
109	Zone fault 16	Rc
110	Keypad fault	Rc
111	Control panel fault	Rc
112	Siren fault	Rc
113	<b>Zone alarm end 1</b>	<b>Rc</b>
114	Zone alarm end 2	Rc
115	Zone alarm end 3	Rc
116	Zone alarm end 4	Rc
117	Zone alarm end 5	Rc
118	Zone alarm end 6	Rc
119	Zone alarm end 7	Rc
120	Zone alarm end 8	Rc
121	Zone alarm end 9	Rc
122	Zone alarm end 10	Rc
123	Zone alarm end 11	Rc
124	Zone alarm end 12	Rc
125	Zone alarm end 13	Rc
126	Zone alarm end 14	Rc
127	Zone alarm end 15	Rc
128	Zone alarm end 16	Rc
129	<b>Zone tamper end 1</b>	<b>Rc</b>
130	Zone tamper end 2	Rc
131	Zone tamper end 3	Rc
132	Zone tamper end 4	Rc
133	Zone tamper end 5	Rc
134	Zone tamper end 6	Rc
135	Zone tamper end 7	Rc
136	Zone tamper end 8	Rc
137	Zone tamper end 9	Rc
138	Zone tamper end 10	Rc
139	Zone tamper end 11	Rc
140	Zone tamper end 12	Rc
141	Zone tamper end 13	Rc
142	Zone tamper end 14	Rc
143	Zone tamper end 15	Rc
144	Zone tamper end 16	Rc
145	Keypad tamper end	Rc
146	Control panel tamper end	Rc
147	Siren tamper end	Rc
148	<b>Zone fault end 1</b>	<b>Rc</b>
149	Zone fault end 2	Rc
150	Zone fault end 3	Rc
151	Zone fault end 4	Rc
152	Zone fault end 5	Rc
153	Zone fault end 6	Rc
154	Zone fault end 7	Rc
155	Zone fault end 8	Rc
156	Zone fault end 9	Rc
157	Zone fault end 10	Rc
158	Zone fault end 11	rc
159	Zone fault end 12	rc
160	Zone fault end 13	rc
161	Zone fault end 14	rc
162	Zone fault end 15	rc
163	Zone fault end 16	rc
164	Keypad fault end	rc
165	Control panel fault end	rc
166	Siren fault end	rc
167	<b>Telephone line trouble</b>	<b>Rc</b>
168	<b>Telephone line trouble end</b>	<b>Rc</b>
169	<b>Control panel failure</b>	<b>Rc</b>
170	<b>End of control panel failure</b>	<b>Rc</b>
171	<b>Periodic test (24 hr. from last com.)</b>	<b>Rc</b>
172	<b>AC failure (in 30 min. after failure)</b>	<b>Rc</b>
173	<b>AC failure end</b>	<b>Rc</b>
174	<b>RF jamming</b>	<b>Rc</b>
175	<b>Wrong code alarm end</b>	<b>Rc</b>
176	<b>RF jamming end</b>	<b>Rc</b>
177	<b>Panic alarm from remote control N.1</b>	<b>Rc</b>
178	Panic alarm from remote control N.2	rc
179	Panic alarm from remote control N.3	rc
180	Panic alarm from remote control N.4	rc
181	Panic alarm from remote control N.5	rc
182	Panic alarm from remote control N.6	rc
183	Panic alarm from remote control N.7	rc
184	Panic alarm from remote control N.8	rc
185	Master code panic alarm	rc
186	User code panic alarm	rc
187	<b>Panic alarm end from remote contr. 1</b>	<b>Rc</b>
188	Panic alarm end from remote control N.2	rc
189	Panic alarm end from remote control N.3	rc
190	Panic alarm end from remote control N.4	rc
191	Panic alarm end from remote control N.5	rc
192	Panic alarm end from remote control N.6	rc
193	Panic alarm end from remote control N.7	rc
194	Panic alarm end from remote control N.8	rc
195	Master code panic alarm end	rc
196	User code panic alarm end	rc
197	<b>Subsystem panic alarm</b>	<b>Rc</b>
198	<b>Subsystem panic alarm end</b>	<b>Rc</b>

## 18.1. Internal structure of Contact ID protocol

The data in the CID protocol has following standardized structure:

**XXXX 18 Q XYZ 01 CCC**

where XXXX is the account code of the installation, 18 is the code identification (identical for all events), Q is a number from 1 to 3, XYZ is the event number, 01 is the subsystem number, CCC event source details (see the table below).

JA-65 event no.	Q XYZ	Event description	possible source in JA-60							
			C	S	c	A	J	L	d	
058	1 110	Fire alarm		x				x		
113	3 110	Fire alarm end		x				x		
177	1 120	Panic alarm	x		x					x
058	1 120	Panic alarm from a detector		x						
197	1 120	Panic alarm in the subsystem						x		
187	3 120	End of the panic alarm	x		x					x
113	3 120	End of the panic alarm from a detector		x						
198	3 120	End of the subsystem panic alarm						x		
058	1 130	Intruder alarm in an instant zone		x						
113	3 130	End of the intruder alarm in an instant zone		x						
058	1 134	Intruder alarm in a delayed zone		x						
113	3 134	End of the intruder alarm in a delayed zone		x						
075	1 137	System tamper alarm	x		x	x	x			x
129	3 137	All system tampers OK	x		x	x	x			x
074	1 138	Wrong access code alarm	x		x				x	x
175	3 138	End of a wrong access code alarm	x		x				x	x
053	1 140	Alarm after powering of the control panel	x							
075	1 144	Detector tamper alarm		x						
129	3 144	All detector tampers OK		x						
094	1 300	Failure (blown fuse in control panel or other general failure)	x		x	x	x	x	x	x
052	3 300	Control panel powering	x							
148	3 300	No failure in the system	x		x	x	x	x	x	x
172	1 301	AC failure	x							
173	3 301	AC switched on	x							
054	1 302	Problem with power in an item			x	x	x			
056	1 302	Back up battery failure in the control panel	x							
057	3 302	End of the back up battery failure	x							
055	3 302	End of the problem with power in the item			x	x	x			
051	1 305	Reset	x						x	
049	1 306	Entering of programming or user mode	x		x					x
050	3 306	End of programming or user mode	x		x					x
058	1 330	Subsystem alarm						x		
167	1 354	Tel. line failure							x	
169	1 354	Failure of communication in the digital bus								x
168	3 354	End of tel. line failure								x
170	3 354	End of a communication failure in the digital bus								x
174	1 355	RF jamming	x							
176	3 355	End of RF jamming	x							
094	1 380	Detector failure		x						
148	3 380	End of all detector failures		x						
094	1 381	Wireless item communication lost		x	x	x	x			
148	3 381	Wireless item communication reestablished		x	x	x	x			
054	1 384	Detector power problem		x						
055	3 384	End of the detector power problem		x						
026	1 401	Disarming	x		x					x
001	3 401	Complete arming	x		x					x
024	3 402	Partial (Home) arming	x		x					x
025	3 408	No code arming	x		x					x
171	1 602	Monitoring station communication testing (in 24 hr.)								x

Event sources specification in the Contact ID protocol:

JA-65 source	mark	code CCC
Wireless sensor	<b>S</b>	001 to 016
Sensor		201 to 216
Controller	<b>c</b>	401 to 408
User code		501 to 514
Control panel	<b>C</b>	701
Wireless siren	<b>A</b>	711
Sub control panel	<b>J</b>	721
Tel. Line	<b>L</b>	731
Digital bus	<b>D</b>	741



## 20. Remote access to the system

The JA-60U modem is used for the remote connection of a personal computer with Comlink software or a JA-60E keypad to a JA-65 control panel using a public telephone line. It is necessary to know the access code for the remote control of a system (see 15.2).

It enables a computer to remotely control a JA-65 in the same way as when it connected directly to the JA-65 PC's output (see 19). Downloading or uploading of extensive data (like event list downloading, digital communicator setting etc.) takes more time compared to a direct PC connection to the control panel.

Instructions about a remote access using the JA-60E you can find in the JA-60E manual.

### 20.1. Establishing connection with a remote control panel by a computer

Start Comlink SW on a computer equipped with a JA-60U modem. The dialing dialog requires the following data:

- telephone number of the called control panel
- dialing method (tone or pulse)
- COM port number to which the modem is connected
- control panel's remote access code (must be identical as code programmed in the control panel - 8 digits)
- select bypassing of answering machine (if this option was programmed in the control panel); if the connection can not be established, try to enter "space" after the last digit
- select call back feature and enter your telephone number, if you want the control panel to call your computer back (that way the end user's telephone line will be charged for the remote access communication)

*"Dialing in" dialog of the Comlink software*

## 21. Recommended Professional installer basic rules

If you install the system for a customer, you should follow these rules:

- make a drawing of intended location of the items, keeping in mind proper protection for the intended area.
- if the customer requests reduction of the system (price reasons etc.), ask for a written confirmation that he does not want the particular items you recommended (to avoid blame and liability if poorly covered area is robbed in the future)
- make a professional installation and do not forget to clean and be tidy.
- it is very important to explain to the customer all functions of the system, to teach to him or her how to program access codes, how to test the system and how to replace batteries in the items
- offer your regular assistance for testing and battery replacement (we recommend annually)
- make a written report signed by the customer, that the installation was finished properly and that she or he received your training on how to operate and test the system

## 22. Trouble shooting table

Problem	possible cause	solution
alarm after first powering	the control panel is not in factory default setting	perform a factory default reset
connected JA-60E keypad has no function	connecting cable does not connect the corresponding positions in the keypad and in the control panel (1-1, 2-2, 3-3, 4-4)	Check the colors of the cores in the cable and positions on each side
impossible to enroll a wireless item	location of the item is not suitable and the radio signal level is too low (too far away or an obstacle is in the way of communication)	change location of the item, (fix it in the new place temporary at first and then try it)
a fault is indicated on the keypad and it is beeping	check display for the reason of the trouble. Press key N to disable beeping. The trouble information is stored in the event memory and it can be reviewed entering F4 anytime in the future	check the reason of the trouble in user manual and fix it, or call the installer
telephone line failure is indicated and the phone works as normal	when you make a phone call longer than 15 minutes, it is interpreted by the system that the tel. line is not ready.	if this problem repeats, disable tel. line checking in programming mode
PIR movement detector repeatedly triggers alarms with no visible reason	check if there are: animals in the protected area (mice...), sudden changes of temperature or intense air circulation, movement of objects with temperature of about 37°C etc.	increase detector's immunity (internal setting), change location of the detector or use an optional sensor's lens
fault or alarm C is indicated	blown fuse in the control panel or radio communication jamming	PC with Comlink SW gives details
when activated, the tel. dialer calls a number multiple times	the telephone network does not use standard recognition signals and the dialer is not sure if the connection was successful or not	store F0 after the last digit of the problematic number
system does not communicate with connected PC	the PC-60A cable is not connected to the correct COM connector on the PC	check the connection or select the port number in SW manually
problem is not in this list	call installer or the distributor for advice	local hot line number:

## 23. Possibilities to extend the system

The JA-65 alarm system is a kit which can be tailor configured according to the size of the house or the needs of the user. It can combine wireless and wire operated components.

### 23.1 Extension of the system with a subsystem

An additional JA-65 or JA-60 control panel can be enrolled as a subsystem to the control panel (see 12.11.). Each system then works as an independent system. However, any event in the subsystem (alarm, tampering, failure or low battery) will trigger the same kind of event on the main control panel (the main control panel will display "J" as the event source). The main control panel will not indicate the number of the item which triggered the event, but this information is available on the subsystem's control panel.

Using this method, multiple level subsystems can be chained.

**Warning:** never enroll the top level control panel as a subsystem of the lower level control panel. This would create endless circle for the data and such an alarm system chain would not work properly.

## 24. Brief overview of parts suitable for the JA-65 system

The following description includes the basic assortment of accessories. Jablotron is systematically introducing new and improved items to the market. You can get the most current information from your distributor or you can visit Jablotron's Internet home page at: [www.jablotron.com](http://www.jablotron.com)

### 24.1. Wireless items - can be used with module 65R

**JA-60N Magnetic door detector** - is equipped with a magnet. Movement of the magnet triggers the internal sensor in the detector. It can trigger an Instant or Delayed intruder alarm and it also has built in tamper detectors. There are inputs for external sensors. It is powered with two AAA batteries, battery life time 1 year, radio communication distance 100m, designed for indoor use.

**JA-60P PIR motion detector** - triggers an Instant or Delayed intruder alarm when the movement of a human body is detected. It has built in tampering sensors and it uses digital processing of the signal for a high false alarm immunity. Coverage 12m/60°. Optional lenses (long corridor, pet zone) are available for this detector. It is powered with two AAA batteries, battery life time 1 year, radio communication distance 100m, designed for indoor use.

**JA-60B Wireless glass break detector** - its sensor covers an entire room (up to 9m), regardless of the number of windows. A dual technology detection method (air pressure and sound analysis) is combined with digital processing to guarantee high sensitivity to the breaking of all types of glass (Plate, Tempered, Laminated, Wired). It is powered with two AAA batteries, battery life time 1 year, radio communication distance 100m, designed for indoor use.

**JA-60S Smoke detector** - triggers a Fire alarm when smoke is detected. It also has a built in siren. A built in ionic chamber ensures high stability of the sensor. It is powered with two AA batteries, battery life time 1 year, radio communication distance 100m, designed for indoor use.

**JA-60G Gas leak detector** - triggers a Fire alarm when any combustible gas is detected (natural gas, city gas, propane, butane etc.). The detector is powered directly from the AC power network and it wirelessly transmits information to the control panel. The JA-60G has a built in siren and an output relay. The relay, for example, can be wired to an electrical valve to turn off the gas supply when a leak is detected. Radio communication distance 50m, designed for indoor use.

**RC-11 Remote control** - this key chain tag sized controller can Arm and Disarm the system. It can also trigger a silent Panic alarm. It is powered by a 6V battery and its working range is up to 30 meters. The RC-11 can also be used separately to control UC receiving modules directly (pulse, latch or ON and OFF modes).

**RC-22 Panic button** - is a large size button, which can be easily attached to a selected location (under a desk, on the wall etc.). This button can be used to trigger a silent Panic alarm. The RC-22 can be enrolled to the control panel the same way as the RC-11 remote control. It has a working range up to 30 meters. The RC-22 can also be used separately to control UC receiving modules directly (pulse, latch or ON and OFF modes).

**RC-60 Remote control** - has two input terminals (A and B) and the tamper input. It can be used to arm and disarm the system remotely from any device providing switching contact output (for example a key operated switch). The RC-60 is powered with two AAA batteries.

**JA-60D Wireless control keypad** - can operate the system in a similar way as the system keypad (arming, disarming, no code arming, partial arming, door opening and under duress operation). It has its own Master code and one User code, which can be programmed independently from the control panel's codes. If the system is split, the keypad can be addressed to section A or B. It is powered with two AAA batteries, battery life time 1 year, radio communication distance 100m, designed for indoor use.

**JA-60F Wireless keypad** - can operate system in exactly the same way as the wired keypad JA-60E. It can also be used for programming and testing of the system. The alarm system's status is indicated by the LED indicators, the built in LED display and buzzer. Illuminated keys can be covered with a bottom - swinging cover. The keypad has TWO-WAY communication with the control panel and it can be enrolled as a controller (positions c1 to c8). Multiple JA-60F keypads can be enrolled to a single control panel. It is powered with four AAA batteries, battery life time 1 year, radio communication distance (open area, no interference) is about 40 meters, indoors the distance from the control panel

should not exceed 10 meters. As an option the keypad can also be powered by a DC adapter (the keys are permanently illuminated in this case).

**Wireless siren JA-60A** is designated for outdoor use. It is powered from its own AC adapter and it has a built in back up battery. The siren wirelessly communicates with the control panel. It contains a high powered siren and a flashing light. Besides signaling alarms, it can also provide arming and disarming chirps. The siren has built in tamper detectors. Only one JA-60A siren can be used with each JA-65 control panel. The siren has cover class IP44 and TWO-WAY communication with the control panel, radio communication distance 100m. An optional external antenna AN-01 can be used with the siren for an even better working range.

**Wireless outputs unit UC-216** is a receiver, which receives signals from the JA-65 control panel. The unit has two output relays (X and Y, max. load 120V / 1A each). These relays have identical functions as outputs PgX and PgY of the control panel. The unit requires external power from 12 to 24VDC or 15VAC. Multiple UC-216's can be used with a control panel and each UC-216 can receive signals from more than one control panel. The module can also be used directly with JA-60 wireless detectors or controllers.

**Wireless output unit UC-222** is a receiver, which receives signals from the JA-65 control panel. The unit has a power output relay (max. 250VAC / 5A). This relay has an identical function as output PgX of the control panel. The unit is powered directly from the AC power (230 VAC). Multiple UC-222's can be used with a control panel and each UC-222 can receive signals from more than one control panel. The module can also be used directly with JA-60 wireless detectors or controllers.

## 24.2. The JA-6x system items:

**JA-60E Wire operated keypad** - can be used to operate and program the system. It is connected to the control panel by a cable. Up to five keypads can be wired to a single control panel. The alarm system's status is indicated by the LED indicators, the built in display and built in buzzer. Illuminated keys can be covered with a closable cover. The keypad can control the system remotely when using the JA-60U modem.

**PC interface cable PC-60A** - can be used to connect the control panel to a serial port (COM) in your computer. Suitable SW, ComLink, is provided on a floppy disk or you can visit Jablotron's Internet home page at: [www.jablotron.com](http://www.jablotron.com) to download a beta version of it. The software is a convenient way to setup the control panel, to supervise the system which is on line, to read, view and store data from the event memory and to record other information about the system. The software can be installed under MS Windows system.

**JA-60U modem** - it is possible to dial in to the control panel from a remote computer equipped with JA-60U modem and Comlink software. Instead of a computer, the JA-60E system keypad can be used, too. Installers mostly use the modem, but end user can use it as well (e.g. for remote arming and disarming etc.). The JA-60U is supplied together with power adapter, PC interface cable and Comlink software. The JA-60E keypad can be plugged directly to the data connector of the modem.

## 24.3. Wire operated items

**SA-200, SA-201 Magnetic door sensors** - can be used as door or window opening sensors. The built in reed contact opens when the magnet more far than 25mm.

**JS-20 Movement detector** - PIR sensor which uses sophisticated signal processing for a high false alarm immunity. Coverage 12m/120°. Optional lenses (long corridor, pet zone) are available for this detector. The detector has a high RF signal immunity, stand by consumption 10mA/12VDC.

**GBS-210 glass break detector** - its sensor covers an entire room (up to 9m), regardless of the number of windows. A dual technology detection method (air pressure and sound analysis) is combined with digital processing to guarantee high sensitivity to the breaking of all types of glass (Plate, Tempered, Laminated, Wired). It has stand by consumption 15mA/12VDC.

**SD-112 Smoke detector** - triggers a Fire alarm when smoke is detected. It also has a built in siren. A built in ionic chamber ensures high stability of the sensor. It has stand by consumption 5mA/12VDC.

**GS-130, GS-133 Gas leak detectors** - trigger a Fire alarm when any combustible gas is detected (natural gas, city gas, propane, butane etc.). The detector has a built in siren and an output relay. The relay, for example, can be wired to an electrical valve to turn off the gas supply when a leak is detected. Model GS-130 is powered directly from the AC power network and model GS-133 is powered from the control panel - 150mA/12V.

**SA-105, SA-107 indoor sirens** - are powerful ordinary piezo sirens with loudness in level of 120dB/1m, power consumption about 250mA/12V.

**OS-300, OS-305 outdoor sirens** - are double covered with backup power supply. External housing is made of a highly resistive polycarbonate. Siren has cover class IP44, built in DC to DC converter for optimal back up battery charging. Both models have loudness in level of 118dB/1m. Model OS-300 uses a magneto-dynamic sounder, OS-305 a piezo one. The siren uses balanced loop type trigger input for higher safety and it has a sophisticated tampering protection.

## 25. Control panel specifications:

### **Electrical**

Power	230 VAC, max 0.35 A, (built in electronic power supply), supervised, protection class II
Backup battery	12 V, from 1.3 to 7 Ah (external up to 40 Ah), supervised, not included
Backup power output for wired items	13VDC, the max. permanent current is 0.7 or 1.2 A for max. 15 min (not more then one cycle per hour)
Hard-wired inputs	module 65H: 8 input zones, up to two 65H modules can be used (16 zones)
Zone input triggering	selectable: NC, End Of Line resistor or Double End Of Line resistor
Zone reaction	selectable: instant, delayed, panic, fire, 24 hour, next delayed

### **Wireless communication**

Working frequency	module 65R: up to 16 detectors (JA-60), 8 controllers, 1 outdoor siren JA-60A 433.92 MHz; digital hopping code; supervised communication
Keypads	max. 5 wired JA-60E keypads, max. 8 JA-60F wireless keypads or RC-11 or JA-60D remote controllers
Access codes	master code and 14 user codes. When system is split, codes, detectors and remote controls can be addressed to particular sectors
Wired outputs	Alarm relay dry contacts 1A/60V; programmable outputs PgX & PgY (Chime, Fire, Arm, Panic, Alarm, Door, Home, AC failure), siren output (12 V, 0.7 A)
Wireless outputs	module 65R transmits signals for siren and PgX, PgY data for UC-2xx receivers
Events memory	127 most recent events including date, time and detailed specification
Telephone communicator	module 65X: digital communication to a monitoring station, Pager dialing, 2 voice messages, modem communication with a remote PC (ComLink SW + JA-60U modem), remote keypad access with JA-60E and JA-60U
Monitoring station formats	Contact ID, Ademco, Telemax, Franklin, Radionics, SurGard, DTMF2300, (198 reports codes)



### **Environmental**

Operating temperature	-10°C to 40° C
Operating humidity	max 80 %
Working environment	indoor use (class II, EN 50131-1)

### **Electronic design**

Design	SMT; modular system (radio module 65R, hardwired zones module 65H, telephone communicator module 65X); full supervision; monitoring of RF jamming
Electrostatic discharge	8 kV
RF immunity	30 V / m

### **Physical**

Housing	metal box with built-in electronic power supply
Dimensions	295 x 280 x 90mm
Shipping weight	2.72kg
Color	white or light gray

### **Standards**

Complies with: EN 50131-1 (Grade 2), EN 50131-6, EN 300220, ETS 300 683, EN 50136, ETS 300001, TBR 21

\*\* can be operated according to ERC REC 70-03

\* can be connected to analogue interfaces TBR 21/1998, EG 201 121 V1.13/2000, AS/ACIF S002/2001 (Australia)

**Hereby, Jablotron Ltd., declares that this JA-65 is in compliance with the essential requirements and other relevant provisions of Directive 1999/5/EC.** Original of the conformity assessment can be found at the web page [www.jablotron.cz](http://www.jablotron.cz), section Technical support.

**Note:** Dispose of batteries safely depending on the type of the batteries and local regulation. Although this product does not contain any harmful materials we suggest you to return the product to the dealer or directly to the producer after usage.