

# ORBIT-6

**INSTALLER MANUAL**

**VER. B**

## **Customer Information**

1. The ORBIT-6 (Model RP-206) complies with FCC Part 68 Rules. On the upper panel of this product is a label that contains, among other information, the FCC Registration Number and Ringer Equivalence Number (REN is 0.8B). If requested, this information must be provided to the Telephone Company.
2. An FCC compliant telephone connector is provided with this equipment. This equipment is designed to be connected to the telephone network or premises wiring using a connector, which is Part 68 compliant.
3. If the ORBIT-6 (RP-206) is not operating properly, it may cause harm to the telephone network. If so, the Telephone Company will notify you in advance that a temporary discontinuance of service may be required. If advance notice is not practical, you will be notified as soon as possible. Also, you will be advised of your right to file a complaint with the FCC if it is necessary.
4. The Telephone Company may make changes in its facilities, equipment, operations, or procedures, which could affect the operation of the equipment. If this happens, the Telephone Company will provide advance notice in order to enable you to make the necessary modifications to maintain uninterrupted service. If the equipment is causing harm to the telephone network, the Telephone Company may request that the equipment be disconnected until the problem is resolved.
5. Connection to telephone company-provided coin service is prohibited. Connection to party line service is subject to state tariffs.
6. If trouble is experienced with the ORBIT-6 (RP-206), for repair and warranty information, please contact your supplier.

**For service centers please see back cover.**

### **FCC Warning**

This equipment has been tested and found to comply with the limits for a Class B digital device pursuant to Part 15 of the FCC Rules. These limits are designed to provide reasonable protection against harmful interference in a residential installation. This equipment generates, uses, and can radiate radio frequency energy and, if not installed and used in accordance with the instructions, may cause harmful interference to radio communications. However, there is no guarantee that interference will not occur in a particular installation. If this equipment does cause harmful interference to radio or television reception, which can be determined by turning the equipment off and on, the user is encouraged to try to correct the interference by one or more of the following measures:

- Reorient or relocate the receiving antenna.
- Increase the separation between the equipment and the receiver.
- Connect the equipment into an outlet on a circuit different from that to which the receiver is connected.
- Consult the dealer or an experienced Radio/TV technician for help.

Changes or modifications to this unit not expressly approved by Rokonet, Ltd., could void the user's authority to operate the equipment.

*This equipment has been approved to Council decision 98/482/EC TBR 21 for pan-European single terminal connection to the Public Switched Telephone Network (PSTN). However, due to differences between the individual PSTNs provided in different countries, the approval does not, in itself, give an unconditional assurance of successful operation on every PSTN termination point.*

*In the event of problems, you should contact your equipment supplier in the first instance.*

Copyright © 2001  
by Rokonet Ltd.,  
14 Hachoma Street  
Rishon Letzion 75655  
Israel

All rights reserved.

No part of this document may be reproduced in any form without prior written permission from the publisher.

5IN206IM B

# Summary of User s Commands

It is necessary to **ARM** your system to obtain protection from **intrusion**.

**All other forms of protection, including fire and 24-hour panic alarms (i.e. police, fire, and medical) are always ready to report alarms and do NOT need to be armed.**

This page, called a **Command Summary**, is intended to give you brief summaries of common system operations. More detailed explanations and related information can be found within, by referring to the user manual.

FUNCTION	PROCEDURE
System Arming	[USER CODE] + [ARM]
Stay Home Arming	[USER CODE] + [STAY]
Instant Stay	[STAY] + [STAY]
System Disarming	[USER CODE]
Duress Disarming	[DURESS CODE]
Silencing an Alarm	[USER CODE]
Bypassing / Unbypassing a Zone	[*] + [ 1 ] + [USER CODE ] + [ ZONE NUMBER TO BE BYPASSED / UNBYPASSED]
Quick Bypassing Zone	[ ZONE NUMBER TO BE BYPASSED ] for at least 2 seconds
Reset Smoke Detector(s)	[*] + [ 2 ] + [USER CODE ] + [UTILITY OUTPUT NUMBER which is responsible for resetting the Smoke Detector]
Utility Output Operation	[*] + [ 2 ] + [USER CODE ] + [ UTILITY OUTPUT NUMBER ]
Display Troubles	[*] + [ 3 ]
Display Memory	[*] + [ 4 ]
Setting/Changing a User Code	[*] + [ 5 ] + [MASTER CODE] + [CODE NUMBER TO BE SET/CHANGED] + [NEW CODE]
Set Date	[*] + [ 6 ] + [ 1 ] + [MASTER CODE] + [MM] [DD] [YY]
Set Time	[*] + [ 6 ] + [ 2 ] + [MASTER CODE] + [H][H] [M][M]
*Set Auto Arm Time	[*] + [ 6 ] + [ 3 ] + [MASTER CODE] + [H][H] [M][M]
Set Follow-Me Phone No. 1	[*] + [ 7 ] + [ 1 ] + [MASTER CODE] + Phone No. + [ #]
Set Follow-Me Phone No. 2	[*] + [ 7 ] + [ 2 ] + [MASTER CODE] + Phone No. + [ #]
**Set Follow-Me Phone No. 3	[*] + [ 7 ] + [ 3 ] + [MASTER CODE] + Phone No. + [ #]
**Set Follow-Me Phone No. 4	[*] + [ 7 ] + [ 4 ] + [MASTER CODE] + Phone No. + [ #]
Maintenance:	
On/Off Buzzer	[*] + [ 8 ] + [MASTER CODE] + [1]
On/Off Door Chime	[*] + [ 8 ] + [MASTER CODE] + [ 2]
*On/Off Audible Kiss-Off Indication	[*] + [ 8 ] + [MASTER CODE] + [ 3]
Get Event From Event Logger	[*] + [ 9 ] + [MASTER CODE] + [EVENT NO.]
Test System	[*] + [ 0 ] + [MASTER CODE]

Trouble Table	LED	Trouble
	1	Low Battery
	2	AC Power Loss
	3	Clock Not Set
	4	Communication Trouble
	5	Bell Loop Trouble

\*New in Version 1.2

\*\*New in Version 1.3

## TABLE OF CONTENTS

Introduction to the ORBIT-6.....	6
Main Features:.....	6
Installation.....	7
Before You Begin.....	7
Technical Data.....	8
Installer Programming.....	9
The keypad.....	9
Restoring Factory Defaults to the ORBIT-6.....	9
Introduction to Programming.....	9
Programming your Orbit-6.....	10
Viewing the Contents of a Location.....	11
Locations Whose Contents Occupy More Than One Digit.....	12
Audible Tones and Error Beeps.....	12
How to program installer parameters.....	12
A Programming Tutorial.....	12
GENERAL SYSTEM PARAMETERS: Locations 00–05.....	14
SYSTEM CODES: Locations 06-10.....	15
SYSTEM TIME: Locations 11-13.....	16
Intrusion Zone Types and Zone Sounds: Locations 14-21.....	16
SPECIAL ZONE TYPES:.....	18
Utility Outputs: Locations 22-25.....	19
Communication Parameters: Locations 20–21.....	22
Digital Communicator Controls: Location 26.....	22
Central Station Protocols: Location 27-28.....	23
Understanding the Code Format.....	24
Upload/Download Rings: Location 29.....	25
System Controls: Location 30.....	25
Periodic Test Time: Location 31.....	27
Communicator Reporting Codes: Locations 32 through 85.....	27

The **ORBIT-6** is intended to address the needs of many homes, offices, and small businesses. Its operation is designed around microprocessor and EEPROM (Electrically Erasable Programmable Read-Only Memory) technology, which stores, without the need for a source of power, the system's operating program and its programmable parameters.

System programming may be performed from any **ORBIT-6** keypad, or from a special LCD Programming Keypad designed specifically for that.

Remote and local system programming is also possible through the use of Rokonet's **ORBIT** Upload/Download software.

### Main Features:

**Zones** (end-of-line resistor required 2200 ohm)

- 6 Programmable Intrusion Zones
- Special type: Zone 5 – Fire Zone, Zone 6 - tamper zone
- One Fixed Panic Zone input on the keypad (not on keypad RP206KL6)
- 3 Keypad Emergency Zones (Panic, Fire, Special Emergency)

**Alarm Sounder Output**

- Programmable Bell/Siren or Loudspeaker Output
- Capacity: 750 mA (maximum)

**Auxiliary Output for Peripheral Devices**

- Capacity 250 mA (maximum)

**Built-In Digital Communicator**

- For Central Station communications (two phone numbers)
- For Upload/Download functions
- For follow-me functions

**Keypads**

- Up to 4 LED/LCD keypads can be connected

**Utility Outputs**

- One transistor-driven (open-collector) triggered output

**Security Codes**

- Two Installer Codes
- One Master (User) Code
- Nine User Codes (all may be used as duress code)

**Periodic Testing**

- Daily test report to central station

**Optional Peripherals**

- Four relay outputs expansion
- Voice Module

**Event Log**

- Event log of 100 events

## INSTALLATION

### Before You Begin

Be sure the actual work is performed by experienced personnel, licensed to carry out security system installations and capable of implementing all applicable requirements of the National Fire Protection Association (NFPA-70 and NFPA-74), as well as any federal, state, and local codes—along with any safety guidelines and regulations which might apply.

### Mounting and Wiring the Control Panel (refer to figures 1A, 1B & 1C on pages 32, 33 & 34)

1. Mount the ORBIT-6's metal cabinet at a protected dry location, near a source of unswitched AC Power, a good ground, and access to telephone service. Use the proper hardware (e.g. anchors, mollies, toggle bolts, etc.), as required, to insure a suitable mounting.
2. Thread all electrical wiring through a convenient hole in the metal cabinet. To prevent potential damage, be sure that live AC power is NOT present and that the Standby Battery is NOT connected. Refer to Figures 1A and 1B. Your wiring may include any and all of the following:
  - connections to Hardwired Zones
  - connections to devices requiring Uninterrupted Auxiliary Power (e.g. PIRs, Glass Break Detectors)
  - connections to Smoke Detectors requiring Resettable Power
  - connections to any External Sounders
3. If using Utility Output, connect the UO/ECL output, this terminal is designed to activate a low current device (e.g. a 12 VDC Relay, drawing no more than 70 mA).  
If using UO expansion module, connect the UO/ECL terminal to the ECL terminal input in the expansion module. In this case the first UO on the expansion module will become UO1. (see figures A1)
4. Make connections from the RJ31X (or equivalent) telephone company interface.
5. Make connections to the system's keypad(s) by the corresponding wire colors.
6. Make connections to AC Power (via a 16.5 VAC, 25 VA transformer). Do not plug in the transformer at this time.
7. Have a Standby Battery ready (typically 12 VDC, 4 AH), but do not connect it at this time.
8. All zone inputs are End Of Line supervised, use 2200 ohm resistors (supplied).
9. When using 8 LED keypad, zones 7 & 8 are end-of-line supervised. Use 2200 ohm resistors (supplied) when the zones are not in use. For further wiring instructions of the 8 LED keypad, refer to Figure 1C on page 34.
10. If using a Key-switch, use a momentary key-switch. The receiver (if used) must give a pulse output and not on/off.
11. To connect the panic button use the white wire as (+) and the black wire as (-).

**Note:** The maximum distance between the panic button and the keypad is 30 meters.

## TECHNICAL DATA

### Main Panel

Input power	16.5 V AC 25 VA via transformer	
Rechargeable standby battery	12 V 4 A-Hours	
Auxiliary Power	12 V DC 250 mA maximum	
Bell/LS Sounder output	12 V DC 750mA maximum	
Programmable output	Open collector Active pull down 70mA maximum	
Cabinet Dimensions:	260X218X83 mm (10.2X5.1X3.3 ")	
Weight	1.84 kg (4 lb)	
Main Board (dimensions / weight):	80X167 mm (3.15X6.6 ")	0.17 kg (0.37lb)
Fuse F1	Auxiliary Power	0.5 A
Fuse F2	Bell/LS Power	1 A
Fuse F3	Battery Power	2 A

### Keypads

	6-Zone Keypad	8-Zone Keypad
Current consumption:	18 mA typical, 30 mA maximum	18 mA typical, 30 mA maximum
Control panel connections:	4-wire up to 300 ft (100 m) from panel	4-wire up to 300 ft (100 m) from panel
Dimensions:	110X130X25 mm (4.3X5.1X1 ")	110X130X25 mm (4.3X5.1X1 ")
Weight:	0.19 kg (0.42 lb)	0.19 kg (0.42 lb)

### Utility Output Expansion Module

	Relay	Transistor
Current consumption:	10mA typical, 50mA max	10mA typical, 15mA max
Control panel connections:	4-wire up to 300 ft (100m) from panel	
Contacts:	4 relays, 0.5 A, 24 V DC	4 O.C., 50 mA, 12 V DC
Dimensions:	53X85 mm (2.1X3.35 ")	
Weight:	80 gr (0.18 lb)	

### Max. Run Length from Panel to Keypad

Wire	AWG	19	20	22
	Ø (mm)	0.9	0.8	0.6
Length	Meter	200	166	100
	Feet	660	547	330

### Bell Loudspeaker Wiring Table (Distance in Feet)

Max. Current mA	18		19		20		22	
	1		0.9		0.8		0.6	
	Feet	Meter	Feet	Meter	Feet	Meter	Feet	Meter
100	780	238	625	190	495	151	310	95
300	260	79	208	64	165	50	103	32
650	120	37	96	30	76	23	48	15

### Detectors Distance in Feet

Max. Current mA	18		19		20		22		24	
	1		0.9		0.8		0.6		0.5	
	Feet	Meter	Feet	Meter	Feet	Meter	Feet	Meter	Feet	Meter
20	3920	1195	3100	945	2460	750	2460	472	1550	296
30	2600	793	2060	628	1640	500	1640	314	1030	197
40	1960	597	1550	472	1230	375	1230	236	775	148

### The keypad



The Orbit-6 can support up to 4 keypads, with a choice of 3 styles, 1 LCD type and two LED types from which virtually all features may be accessed. In addition to the functions it provides for the user, each of the keypads can be used by an installer to program the system parameters.

An attempt to enter an incorrect series of keystrokes will result with 3 error beeps.

All program location values (data) are displayed by zone indicators on the LED keypad in binary format.

### Restoring Factory Defaults to the ORBIT-6

1. Your **ORBIT-6** and at least one LED Keypad should already be wired together and/or physically installed
2. Remove all power from the Printed Circuit
3. Place the **ORBIT-6**'s J1 (DEFAULT) jumper over both corresponding pins. (See Figures 1A and 1B **on page 32 and 33** ).
4. Reapply power (AC and/or Standby Battery) to the PC Board.
5. After a short beep is heard, remove the J1 jumper. The **ORBIT-6**'s default settings are now restored.
6. Check that the POWER LED is flashing. Depending on the state of the system, the READY LED and the Zone LEDs may or may not be lit.

### Introduction to Programming

First, check that the panel's J1 (DEFAULT) jumper is NOT covering both pins on the PC Board.

The ORBIT-6 stores information in 86 programming locations.

The data stored in any location is represented by numbers and/or letters. Some locations require just one digit, while most require two. Others (e.g. those used to store phone numbers and account numbers) may require several more digits.

It is not necessary to enter data into all 86 categories. Many locations have been factory-programmed with default parameters.

Note that power can be removed from the ORBIT-6, as its memory does not require a source of power to retain its information.

## Programming your Orbit-6

### Programming Methods

Local	Requirements
<p><b>LED or LCD keypads</b></p>	<p>The keypad must be wired to the Orbit-6 panel. Power must be applied to the Orbit-6.</p>
<p><b>Orbit Programmer</b> Easy programming of the control panel parameters with menu driven LCD display. The programmer can store up to 10 Orbit-6 programming sets and copy it directly to the panel. The programmer supports both the Orbit-5 and Orbit-6 panels.</p>	<p>The programmer will be connected and receive its power from the panel.</p>
<p><b>Orbit UD*</b> Local Up/Load Windows version from a personal computer.</p>	<p>The software must be installed and an Orbit UD Adaptor cable is connected between the panel and the computer.</p>
Remote	Requirements
<p><b>Orbit UD*</b> Remote U/D Windows version from a personal computer.</p>	<p>The software and applicable modem with configured access to a telephone line must be installed.</p>
<p>* Compatible with Windows 95/98/2000 &amp; NT.</p>	

## Viewing the Contents of a Location

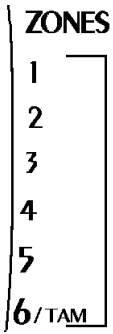

It's often necessary to check the data stored in a memory location to be sure it's correct. If improper data is found, it must be corrected in order to obtain the desired system response. The data in a location can either be a number (from 0-9) or a letter (from A-F). Doing so takes advantage of the hexadecimal numbering system. For our purposes, the characters A through F will be referred to as hexadecimal digits.

Whenever the Installer Programming mode is active, the first 4 keypad's Zone LEDs (1-4) are used to reveal each digit in a selected location. By adding up the values assigned to the lit LEDs, the contents of any location can be determined. See table below.

ZONE LEDs				
I.D.:	4	3	2	1
Value:	8	4	2	1
0	off	off	off	off
1	off	off	off	ON
2	off	off	ON	off
3	off	off	ON	ON
4	off	ON	off	off
5	off	ON	off	ON
6	off	ON	ON	off
7	off	ON	ON	ON

ZONE LEDs				
I.D.:	4	3	2	1
value:	8	4	2	1
8	ON	off	off	off
9	ON	off	off	ON
A	ON	off	ON	off
B	ON	off	ON	ON
C	ON	ON	off	off
D	ON	ON	off	ON
E	ON	ON	ON	off
F	ON	ON	ON	ON

EXAMPLE: Zone 4-ON Zone 3-off Zone 2-off Zone 1-ON      TOTAL = 9  
 EXAMPLE: Zone 4-ON Zone 3-off Zone 2-ON Zone 1-ON      TOTAL = B

### Hexadecimal Digits

In some locations you may be required to enter hexadecimal digits A - F to do so see the next table.

- "A" is entered by pressing [STAY] + [1]
- "B" is entered by pressing [STAY] + [2]
- "C" is entered by pressing [STAY] + [3]
- "D" is entered by pressing [STAY] + [4]
- "E" is entered by pressing [STAY] + [5]
- "F" is entered by pressing [STAY] + [6]

## Locations Whose Contents Occupy More Than One Digit

When a location contains more than one digit, they cannot be viewed simultaneously. As soon as a location is accessed, the first digit is displayed automatically. Additional digits (if they exist) can be displayed by pressing the following keys:

**STAY** **STAY**

Used to display the next digit in a location containing at least two digits; e.g. if 5-6-7-8 is stored in a location, the "5" is displayed first; by pressing **STAY** **STAY**, the "6" will be displayed; continue this process to display the entire contents of the chosen location. Error beeps will be produced when it's attempted to display digits which don't exist

**STAY** **ARM**

Used to move backwards among the digits stored in a location containing at least two digits. Error beeps will be produced when it's attempted to display digits which don't exist

## Audible Tones and Error Beeps

To confirm an operation, a single, long beep will be heard. However, any improper use of the keypad resulting in an error or an unacceptable response will produce three rapid beeps. If heard, repeat the operation or exit the programming mode and try again.

## How to program installer parameters

1. To enter the Installer programming mode:  
Press 4 digit Installer code followed by # (factory default **0 2 0 6**)
2. To move to a new location:  
Press two digits of location followed by ARM
3. To enter data into the location:  
Press data digits (0 - 9 digits including hexadecimal A-F) followed by #
4. To exit programming mode:  
Press 4 digit installer code followed by ARM

## A Programming Tutorial

To get acquainted with some programming basics, a short tutorial has been prepared. It involves changing the Installer Code from the factory default of **0-2-0-6** to a sequence of your own choosing. If you can master this operation, subsequent programming should be easy.

	Operation	Action	Comments			
1	Enter the Installer Programming mode	enter the factory default Installer Code (0-2-0-6); followed by #	a long beep will sound, confirming successful entry into Installer Programming			
2	Access the current Installer Code (stored in location "08")	press [0], [8], [ARM]	no confirming beep will sound			
3	Enter a unique Installer Code (for this tutorial, we'll use 3-0-5-7)	enter [3], [0], [5], [7]	no confirming beep will sound			
4	Store the data you have entered	press [#]	a long beep will sound confirming that data has been properly stored if a wrong number of digits entered three (error) beeps will sound after pressing #			
5	Check the data stored in Location "08"	<ul style="list-style-type: none"> <li>the first digit of the stored data will appear</li> <li>observe the Zone LEDs</li> <li>press [STAY] [STAY] to advance to the next digit</li> <li>once all four digits have been displayed, attempts to view an additional digit will result in three (error) beeps</li> <li>if desired, press [STAY] and [ARM] to move backwards</li> </ul>	press keys	displayed	zone LEDs lit	value
			none	1 <sup>st</sup> digit	2, 1	3
			STAY STAY	2 <sup>nd</sup> digit	none	0
			STAY STAY	3 <sup>rd</sup> digit	3,1	5
			STAY STAY	4 <sup>th</sup> digit	3,2,1	7
6	Go to another location of your choice	press the desired two-digit location and [ARM]	press [ARM] alone to go to the next sequential location			
7	Exit programming	enter your Installer Code and press [ARM]	a long beep will confirm your actions			





<b>Location: 09</b>	<b>Installer Code II</b>	<b>Default: 1206</b>
---------------------	--------------------------	----------------------

**Same as the** Installer Code 1, but with a few limitations: It can't modify the "default code", observe and modify the first installer's codes, modify any MS phone number, nor observe & modify MS lock code.

Installer Code

<b>Location: 10</b>	<b>Master Code</b>	<b>Default: 1234</b>
---------------------	--------------------	----------------------

**PURPOSE:** to establish the keypad code for the system's "chief user"; the Master Code provides the following special privileges:

- to enter, modify, and delete the remaining nine User Codes
- to set the system's internal clock
- to perform certain system functions and tests

Master Code

**Note:** the Master Code cannot be seen by the installer through the zone LEDs on the keypad.

### SYSTEM TIME: LOCATIONS 11-13

<b>Location: 11</b>	<b>Exit Delay</b>	<b>Default: 030</b>
---------------------	-------------------	---------------------

**PURPOSE:** to establish the system's Exit Delay (the interval, in seconds, between entering a User Code at the keypad and when the system actually arms).

Enter three digits between 001 and 255 seconds

Exit Delay

<b>Location: 12</b>	<b>Entry Delay</b>	<b>Default: 060</b>
---------------------	--------------------	---------------------

**PURPOSE:** to establish the system's Entry Delay (in an armed system, the interval, in seconds, between the moment an entry door is opened and an alarm is triggered).

Enter three digits between 001 and 255 seconds

Entry Delay

<b>Location: 13</b>	<b>Bell Cutoff Time</b>	<b>Default: 04</b>
---------------------	-------------------------	--------------------

**PURPOSE:** to set the interval that the system's external sounder(s) will operate before it shuts off automatically.

Enter the number of minutes between 01 and 90

Sounder  
Cutoff

### INTRUSION ZONE TYPES AND ZONE SOUNDS: LOCATIONS 14-21

Locations 14 through 21 are identical and are corresponding to Zones 1 through 6 or 8 (in the 8-zone keypad), respectively. Each of these locations contains two digits.

- the **first digit:** Contains the number used to represent the Type of Zone desired
- the **second digit:** Contains the number used to represent the sound produced when in alarm

**Note:** 1. When using 6 zone keypad the system disregards zones 7 - 8.  
 2. When using 8 zone keypad, zones 7 - 8 must be connected to an EOL resistor when not in use.

Locations: 14-21	Zone 1-8: (1 <sup>st</sup> Digit): Type	Default:
1 <sup>st</sup> Digit	Zone Type and Comments	
<b>0</b>	<b>Not Used</b> All unused zones should be given this designation. It is also used to disable a zone	
<b>1</b>	<b>24-Hour</b> A violation of such a zone will always cause an instant intrusion alarm, regardless of the system's armed/disarmed state	
<b>2</b>	<b>Instant (Intrusion)</b> Causes an immediate intrusion alarm if violated when the system is in arm state. Entry Delay.	
<b>3</b>	<b>Entry/Exit Delay</b> If violated, a zone with this designation will not cause an intrusion alarm during the Entry and Exit Delay periods	
<b>4</b>	<b>Exit (OPEN)/Entry</b> Such a zone behaves as described above in Entry/Exit Delay, except that if faulted at the time the system is armed, it will be bypassed and NOT prevent system arming. To avoid an intrusion alarm, however, it must be secured before the expiration of the Exit Delay period (Location 11).	
<b>5</b>	<b>Entry Follower</b> A zone(s) given this designation will cause an immediate intrusion alarm when violated unless an Entry/Exit zone was violated first if so, an Entry Follower zone(s) will remain bypassed until the end of the Entry Delay period	
<b>6</b>	<b>Interior + Entry Delay Follower</b> If the system is armed to <b>AWAY (ARM)</b> mode: this type of zone behaves like the Entry Follower, described above If the system is armed to the <b>STAY</b> mode: this type of zone will be bypassed Important Note: When arming with "STAY" mode it is possible for the user to eliminate the entry delay period by pressing the (STAY) key twice in succession when arming the system.	
<b>7</b>	<b>Fire Zone</b> Intended for smoke or other types of fire detectors. If violated, will cause an immediate fire alarm. Only Zone 5 can be programmed as a fire zone. A fault in the wiring of any fire zone, if supervised, will cause a fire alarm, manifested by a rapid flashing of the keypads' Fire LED.	
<b>8</b>	<b>Tamper Zone</b> Only Zone 6 can be a Tamper Zone. It operates the same as 24 hours Zone, but this type has a special reporting code.	
<b>9</b>	<b>Panic Zone</b> If violated an immediate panic alarm will be announced.	
<b>A</b>	<b>Key-switch Zone - Instant</b> If desired for system arming and disarming an external SPST spring - loaded, normally open, momentary type key switch can be added. The key switch permits an instant arm and disarming of the system after tripping.	
<b>B</b>	<b>Key-switch Zone - Delayed</b> Such a zone behaves as described above in "key switch zone instant", except when arming the system an exit delay will follow.	
<b>**C</b>	<b>Latch-Key-switch Zone Instant:</b> If desired for system arming/disarming, connect an external SPST latching type (non-momentary) key-switch to any zone terminals, given this designation.	
<b>**D</b>	<b>Latch-Key-switch Zone Delayed:</b> Such a zone behaves as described above in "latched key switch zone instant", except when arming the system an exit delay will follow.	

\*\* New in Version 1.3

Locations: 14-21	Zone 1-8: (2 <sup>nd</sup> Digit): Sound	Default:
2 <sup>nd</sup> Digit	Zone Sound and Comments	
<b>0</b>	<b>Silent</b> a violation during the armed period will produce no sound the resulting alarm can still be reported to the Central Station	
<b>1</b> <b>(default)</b>	<b>External Sounder (Continuous)</b> causes the external sounding device to annunciate steadily, without breaks in the sound cadence the sound will continue until the sounder "times out" or the system is disarmed	
<b>2</b>	<b>External Sounder (Pulses)</b> causes the external sounding device to produce a pulsed (or staggered) annunciation this sound is usually recommended for fire alarm annunciation	
<b>3</b>	<b>Keypad Sounder Only</b> causes the piezo sounder within the system's keypad(s) (only) to beep rapidly	
<b>4</b>	<b>External Sounder + Keypad Sounder</b> causes the external sounding device to annunciate continuously, without breaks in the sound cadence causes the piezo sounder within the system's keypad(s) to beep rapidly	
<b>5</b>	<b>External Sounder When Armed / Keypad Sounder When Disarmed</b> related to 24H zones when alarm during disarm, the keypad's buzzer will be activated when alarm during armed system, the external sounder will be activated	
<b>6</b>	<b>Door Chime</b> assigned to an opening which, when violated during the disarmed period, will cause the system's keypad(s) to beep once during an alarm, the external sounding device will annunciate continuously, without interruption. When alarm occurs during armed system only the external sounder will be activated.	

Zone	Location	Type	Sound
Z1	14	(3)	(1)
Z2	15	(5)	(1)
Z3	16	(2)	(1)
Z4	17	(6)	(1)
Z5	18	(2)	(1)
Z6	19	(2)	(1)
Z7	20	(0)	(0)
Z8	21	(0)	(0)

\* (x) define the type and sound default

### SPECIAL ZONE TYPES:

#### Location: 18 Zone 5: Fire Zone

Zone 5 is reserved as a *Fire Zone*, supports four-wire *Smoke Detectors*. Smoke Detector power must be interruptible in order to reset a detector "latched" in alarm. As such it should be derived from the UO/ECL or one of the UOs terminal (see Figures 1A and 1B). The related UO should be defined as AUX power switch.

#### Location: 18 Zone 5: (1<sup>st</sup> Digit): Type Default: Fire

1 <sup>st</sup> Digit	Zone Type and Comments
<b>7</b>	<b>Fire</b> A fire zone cannot be disabled or bypassed. A fault in the wiring to the zone will cause a Fire Trouble (fire LED blinks). A short in the zone wiring will cause a fire alarm.

**Location: 18 | Zone 5: (2<sup>nd</sup> Digit): Sound | Default: External Sounder (Pulses)**

For fire zone the recommended (default) zone sound is “External sounder pulsed”  
 However it is possible to change the zone sound and type to any of the ones provided in the previous list.

**Location: 19 | Zone 6: Tamper Zone**

Zone 6 is reserved as a Tamper Zone. This zone can be programmed to any zone type (except Fire) including Tamper. If the zone was programmed as Tamper, in violation, a Tamper Code report will be sent and the Tamper LED on the keypad (marked as 6/Tmp) will light up.

**UTILITY OUTPUTS: LOCATIONS 22-25**

The ORBIT-6 supports one open collector *Utility Output* (derived between the UO/ECL and AUX terminals) which can be used for switching an external device on or off. Once the Utility Output is activated the device will be connected between AUX (+12V) and ground (0V). This connection is capable of switching light loads of no more than 70mA.

**Note:** When activated the utility output is switched to the Negative Polarity.

The “UO” can be also used to reset a “latched” Smoke Detector(s). In that case the 12V power to the smoke detector will be supplied via the UO (see Figures 1A and 1B). The UO should be defined as AUX switch.

If the Utility Output Expansion Module is being used, the same information in Location 22 is applicable for the programming of UO2 (Location 23), UO3 (Location 24), and/or UO4 (Location 25). It is not necessary to program all of the available “UOs”, unless they’re used. Note that when the Utility Output Expansion Module is employed, the original Utility Output on the Main Board (the UO/ECL terminal) is no longer available.

**Important: In order to use the Utility Output Expansion Module you have to define the module in Location 30.**

**USING THE ORBIT-6 TO POWER A STROBE**

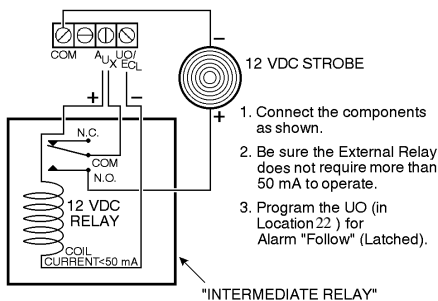

1. Connect the components as shown.
2. Be sure the External Relay does not require more than 50 mA to operate.
3. Program the UO (in Location 22 ) for Alarm "Follow" (Latched).

Because of the “UO’s” modest 70 mA current capability, it will be necessary to use an “intermediate” relay-whose physical contacts can switch far greater currents (limited by their contact rating). The figure at the left shows how such a relay can trigger a strobe light. If used in this manner, the “UO” *cannot* be used to reset a “latched” Smoke Detector(s).

If more than one “UO” output is necessary, a *Utility Output Expansion Module* is available. Its four “UOs” (UO1, UO2, UO3, and UO4) replace the ORBIT-6’s single “on-board” UO”. The “UOs” on the *Utility Output Expansion Module* are relay-based, and allow a maximum current of 500 mAs. Refer to Figures 1A and 1B (**pages 32 and 33**), for wiring instructions and additional information. The figure at the right, shows how a Utility Output on the “UO Expander” can be used to switch a table lamp on and off.

**TURNING ON A LAMP WHEN DISARMING**

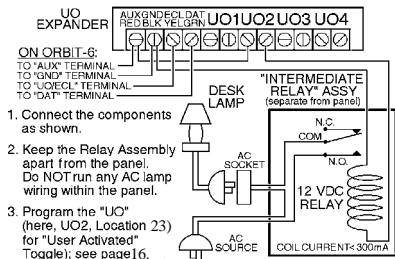

1. Connect the components as shown.
2. Keep the Relay Assembly apart from the panel. Do NOT run any AC lamp wiring within the panel.
3. Program the “UO” (here, UO2, Location 23) for “User Activated” Toggle; see page 16.

Digit	Event and Result
<b>00</b> (default)	<b>Not Active</b> UO offers no response to any system activity
<b>01</b>	<b>Arm Follow (Latch)</b> UO is activated when the system is armed. The activation occurs after the expiration of the exit/delay period. The UO remains active (latched) while the system is armed. When disarming the system the UO deactivates (unlatches).
<b>02</b>	<b>Arm Follow (Pulse)</b> UO is activated when the system is armed. The activation occurs after the expiration of the exit/delay period. The UO is activated for several seconds (pulse), after which is deactivated.
<b>03</b>	<b>Alarm Follow (Latched)</b> UO is immediately activated when the system goes into any type of alarm (i.e. intrusion, fire, keypad-initiated panic) UO remains active (latched) for the duration of the alarm-even after the system's sounder "times out" UO is deactivated when the system is disarmed
<b>04</b>	<b>Alarm Follow (Pulse)</b> UO is immediately activated for several seconds and then deactivated whenever the system goes into any type of alarm (i.e. intrusion, fire, keypad-initiated panic)
<b>05</b>	<b>Zone 1 Alarm Follow (Latched)</b> UO is immediately activated when an alarm occurs on Zone 1. UO remains active (latched) for the duration of the alarm - even after the system sounder "times out". UO is deactivated when Zone 1 goes into normal condition.
<b>06</b>	<b>Zone 1 Alarm Follow (Pulsed)</b> UO is immediately activated for several seconds (pulsed) and then deactivates whenever Zone 1 goes into alarm.
<b>07</b>	<b>Zone 2 Alarm Follow (Latched)</b>
<b>08</b>	<b>Zone 2 Alarm Follow (Pulsed)</b>
<b>09</b>	<b>Zone 3 Alarm Follow (Latched)</b>
<b>0A</b>	<b>Zone 3 Alarm Follow (Pulsed)</b>
<b>0B</b>	<b>Zone 4 Alarm Follow (Latched)</b>
<b>0C</b>	<b>Zone 4 Alarm Follow (Pulsed)</b>
<b>0D</b>	<b>Zone 5 Alarm Follow (Latched)</b>
<b>0E</b>	<b>Zone 5 Alarm Follow (Pulsed)</b>
<b>0F</b>	<b>Zone 6 Alarm Follow (Latched)</b>
<b>10</b>	<b>Zone 6 Alarm Follow (Pulsed)</b>
<b>11</b>	<b>Zone 7 Alarm Follow (Latched)</b>
<b>12</b>	<b>Zone 7 Alarm Follow (Pulsed)</b>
<b>13</b>	<b>Zone 8 Alarm Follow (Latched)</b>
<b>14</b>	<b>Zone 8 Alarm Follow (Pulsed)</b>
<b>15</b>	<b>Panic Follow (Latched)</b> UO is activated immediately when a PANIC alarm is triggered by a violation of a zone, defined as Panic, or by pressing the keypad's [1] and [2] keys simultaneously for two seconds. UO is deactivated when the system is disarmed.
<b>16</b>	<b>Panic Follow (Pulse)</b> UO is activated for several seconds when a PANIC alarm is triggered by a violation of a zone, defined as Panic, or by pressing the keypad's [1] and [2] keys simultaneously for two seconds.

<b>17</b>	<b>Special Emergency Keying Follow (Latched)</b> UO is activated immediately when pressing the keypad's [7] and [8] keys simultaneously for two seconds. UO is deactivated when the system is disarmed.
<b>18</b>	<b>Special Emergency Keying Follow (Pulsed)</b> UO is activated for several seconds when pressing the keypad's [7] and [8] keys simultaneously for two seconds.
<b>19</b>	<b>Fire Keying Follow (Latched)</b> UO is activated immediately when a Fire alarm is triggered by a violation of zone 5, defined as Fire, or by pressing the keypad's [4] and [5] keys simultaneously for two seconds. UO is deactivated when the system is disarmed.
<b>1A</b>	<b>Fire Keying Follow (Pulse)</b> UO is activated when a Fire alarm is triggered by a violation of zone 5, defined as Fire, or by pressing the keypad's [4] and [5] keys simultaneously for two seconds.
<b>1B</b>	<b>User Activated (Toggle)</b> UO may be activated by the user through the entry of [*]+[2]+[User Code]+[X], where X refers to the utility output number. The first entry of the above sequence activates the UO and causes it to latch in the opposite of its current state. The system briefly lights the Zone LED corresponding to the selected UO and produces a single confirming beep subsequent entries toggle the response from ON to OFF to ON, etc.
<b>1C</b>	<b>User Activated (Pulse)</b> UO may be activated by the user through the entry of [*]+[2]+[User Code]+[X], where X refers to the utility output number. The entry activates the UO for several seconds (pulse). The system briefly lights the Zone LED corresponding to the selected UO and produces a single confirming beep subsequent entries repeat this pattern.
<b>1D</b>	<b>AUX POWER Switch (Fire)</b> Until triggered, UO is normally activated and is designed to be a part of the circuit supplying power to the Smoke Detector(s); see Figure 1A and 1B. After a Fire Alarm is disarmed, it may be necessary to reset any Smoke Detector(s) which may be "latched" in alarm. A "latched" Smoke Detector will cause the keyboard's FIRE LED to remain lit, even though the panel may be disarmed. To reset a Smoke Detector, a "UO" used in this manner must be momentarily deactivated; this action is performed by the user, who must enter [*]+[2]+[User Code]+[X], where [X] refers to the UO number (i.e. 1,2,3, or 4) in the circuit providing Smoke Detector power. If this is not done, it will be impossible to arm the panel; please advise your customer of this contingency which is stated in the ORBIT-6's User Manual.
<b>1E</b>	<b>Duress Code Follow (Pulse)</b> UO is activated for several seconds (and then deactivates) when any duress code is entered.
<b>1F</b>	<b>AC Loss Follow (Latched)</b> UO is activated due to a lack of power from the commercial AC. UO is deactivated when the system is operating properly from commercial (AC) power.
<b>20</b>	<b>AC Loss Follow (Pulse)</b> UO is activated for several seconds (and then deactivates) due to a lack of power from the commercial AC.
<b>21</b>	<b>Low Battery Follow (Latched)</b> UO is activated due to low power from the backup battery. UO1 is deactivated when the battery is in good condition.
<b>22</b>	<b>Low Battery Follow (Pulse)</b> UO is activated for several seconds due to low power from the backup battery.
<b>23</b>	<b>Voice Module Enable</b> The UO is activated after FM phone number dialing has been made due to alarm. The UO deactivates after the FM period termination.

<b>24</b>	<b>Duress Code Follow (Latched)</b> UO is activated when any duress code is entered. The UO deactivates either when arming the system or disarming the system due to an alarm that was activated from the emergency keypad keys, 24-hour zone violation or tamper zone violation.
<b>25</b>	<b>Follow Chime (Pulse)</b> (Ver. 1.2) UO is activated for several seconds whenever a keypad sounds its chime.
<b>26</b>	<b>Follow Bell Latched NO</b> (Ver. 1.2) UO is activated whenever the bell is activated. UO is deactivated at the bell cut-off time.
<b>27</b>	<b>Follow Bell Latched NC (Ver.1.3)</b>
<b>28</b>	<b>Follow Ready NO (Ver.1.3)</b> UO is activated whenever the system is in the ready state.

Locations:	22	23	24	25
	UO1	UO2	UO3	UO4
	Action	Action	Action	Action
	<input type="text"/>	<input type="text"/>	<input type="text"/>	<input type="text"/>

## COMMUNICATION PARAMETERS: LOCATIONS 26 29

Locations 26 and 27 allow you to define the manner in which the ORBIT-6 communicates with the Central Station when it reports alarms, restorals, troubles, openings/closings, and tests.

### Digital Communicator Controls: Location 26

- **First digit:** determines the number (or hexadecimal digit) corresponding to the Dialing Method / Duty Cycle / Redial Time desired
- **Second digit:** determines the number corresponding to the Attempts / Answering Machine Use / UL Installation

Attempts	Answering Machine in Use	UL Installation	Voice Module
<i>Attempts</i> sets the number of times the ORBIT-6 will redial the Central Station after failing to establish a successful communication.	If enabled to defeat an answering machine, two phone calls must be made to the premises. On the first call let the phone ring once (by pushing the space bar on the U/D software keyboard). The panel detects this ring and starts a 60sec timer during which the panel will answer the next call on the first ring.	If the ORBIT-6 is installed in accordance with UL requirements, for a Residential Installation (UL 1641), the operation of the unit's Digital Communicator must be modified so as to disable features, which are inappropriate.	If enabled ("YES") voice messages will be sent. If "NO" then tones will be used to represent an active alarm.

Location: 26	Dialer Controls: (1 <sup>st</sup> Digit):		
1 <sup>st</sup> Digit	Dialing Method	Duty Cycle	* Redial Central Station
8	DTMF	N/A	after 60 seconds
1	Pulse @ 20 pps	67/33	after 30 seconds
9	Pulse @ 20 pps	67/33	after 60 seconds
4 (default)	DTMF	N/A	after 30 seconds
5	Pulse @ 20 pps	61/39	after 60 seconds
D	Pulse @ 20 pps	61/39	after 60 seconds
3	Pulse @ 10 pps	67/33	after 30 seconds
B	Pulse @ 10 pps	67/33	after 60 seconds
7	Pulse @ 10 pps	61/39	after 30 seconds
F	Pulse @ 10 pps	61/39	after 60 seconds

\* *redial* refers to the number of seconds the ORBIT-6 will wait before redialing a busy or unresponsive Central Station phone number.

Location: 26		Dialer Controls: (2 <sup>nd</sup> Digit):		
2 <sup>nd</sup> Digit	Attempts	Answering Machine	UL Installation	Voice Module
0	3	No	No	No
1	8	No	No	No
2	3	Yes	No	No
3 (default)	8	Yes	No	No
4	3	No	Yes	No
5	8	No	Yes	No
6	3	Yes	Yes	No
7	8	Yes	Yes	No
8	3	No	No	Yes
9	8	No	No	Yes
A	3	Yes	No	Yes
B	8	Yes	No	Yes
C	3	No	Yes	Yes
D	8	No	Yes	Yes
E	3	Yes	Yes	Yes
F	8	Yes	Yes	Yes

### Central Station Protocols: Location 27-28

Format Name	(PPS) pulses/sec	Kissoff/ Handshake	Validation	InterDigit Time	Code format
Silent Knight/ ADEMCO Slow	10	1400Hz	Dual round	650	0F
Silent Knight/ ADEMCO Slow Extended	10	1400Hz	Dual round	650	4F
Radionics/DCI/ Franklin slow	10	2300 Hz	Dual round	650	17
Silent Knight Fast	20	1400 Hz	Dual round	650	0E
Silent Knight Fast Extended	20	1400 Hz	Dual round	650	4E
Sescoa/Franklin/Vertix/ DCI fast	20	2300Hz	Dual round	650	16
Sescoa/Franklin/Vertix/DCI Extended	20	2300Hz	Dual round	650	56
Universal high speed	20	2300Hz	Dual round	390	12
Radionics	20	1400 Hz	Dual round	390	02
Radionics	20	2300Hz	Dual round	390	12
Radionics Extended	20	1400 Hz	Dual round	390	42
Radionics Extended	20	2300Hz	Dual round	390	52
Radionics	40	1400 Hz	Dual round	390	00
Radionics	40	2300Hz	Dual round	390	10
Radionics Extended	40	1400 Hz	Dual round	390	40
Radionics Extended	40	2300Hz	Dual round	390	50
Radionics	40	1400 Hz	Parity	390	20
Radionics	40	2300Hz	Parity	390	30
Radionics Extended	40	1400 Hz	Parity	390	60
Radionics Extended	40	2300Hz	Parity	390	70

**Example:** to use ADEMCO slow enter 0F to location 27

## Understanding the Code Format

To understand and modify the Code format according to a specific central station see the following

- **First digit:** determine the number corresponding to the desired combination of: Kissoff/Handshake Freq / Message Validation / Extended–Non-Extended Format)
- **Second digit:** determine the number (or letter) corresponding to the desired combination of: Dialing Rate / Interdigit Time / Data Frequency

### Location: 27 CS Protocols: (1<sup>st</sup> Digit):

1 <sup>st</sup> Digit	Format	Kissoff/Handshake Freq	Message Validation
0 (default)	Non-Extended	1400 Hz	Dual Round Compare
1	Non-Extended	2300 Hz	Dual Round Compare
2	Non-Extended	1400 Hz	Parity
3	Non-Extended	2300 Hz	Parity
4	Extended	1400 Hz	Dual Round Compare
5	Extended	2300 Hz	Dual Round Compare
6	Extended	1400 Hz	Parity
7	Extended	2300 Hz	Parity

### Location: 27 CS Protocols: (2<sup>nd</sup> Digit):

2 <sup>nd</sup> Digit	Data Rate	Interdigit Time	Data Frequency
0 (default)	40 pulses/sec	390 ms	1800 Hz
1	33 pulses/sec	390 ms	1800 Hz
2	20 pulses/sec	390 ms	1800 Hz
3	10 pulses/sec	390 ms	1800 Hz
4	40 pulses/sec	650 ms	1800 Hz
5	33 pulses/sec	650 ms	1800 Hz
6	20 pulses/sec	650 ms	1800 Hz
7	10 pulses/sec	650 ms	1800 Hz
8	40 pulses/sec	390 ms	1900 Hz
9	33 pulses/sec	390 ms	1900 Hz
A	20 pulses/sec	390 ms	1900 Hz
B	10 pulses/sec	390 ms	1900 Hz
C	40 pulses/sec	650 ms	1900 Hz
D	33 pulses/sec	650 ms	1900 Hz
E	20 pulses/sec	650 ms	1900 Hz
F	10 pulses/sec	650 ms	1900 Hz

<b>Location: 28</b>	<b>CS Protocols:</b>
---------------------	----------------------

When selecting a contact ID & SIA format, all the reporting codes will be automatically applied to the locations of the reporting codes.

To change a code, enter a new code (according to the type of event – see page 30) to the corresponding location.

When selecting the Pulsed Protocol the default for all the reported codes will be “00” and any other code should be entered manually

To remove a particular reporting code from any of the 3 Protocols enter “00” into the corresponding location.

**Important:** Choose the code format only after defining the zone parameters. Changing a zone type after selecting the code format **WILL NOT** change the zone’s reporting code and a faulty report will be sent to the central station.

Digit	Format Name	Interdigit Time	Data Frequency
00	Pulsed Protocol		
01	Contact ID	NA	NA
02	SIA	390 ms	1800 Hz
**03 (Ver. 1.3)	Ademco 4/2 Express		

### Upload/Download Rings: Location 29

Location 29 sets the number of rings that the ORBIT-6 will wait before automatically answering an incoming call. If such a call was initiated by the alarm company’s Upload/Download software, a process begins which allows a Remote Programming session to take place.

<b>Location: 29</b>	<b>Number of Rings</b>	<b>Default: 12</b>
---------------------	------------------------	--------------------

Choose a number of rings greater than that which the customer will normally wait to answer an incoming call enter two digits; (between 00-15 rings)

Note: if an Answering Machine is in use and so programmed (see Location 26 / 2<sup>nd</sup> Digit), entries made in this location will be ignored

Number of Rings	<input type="text"/>	<input type="text"/>
-----------------	----------------------	----------------------

### SYSTEM CONTROLS: LOCATION 30

Location 30 allows you to specify some additional parameters, which determine how the ORBIT-6 will operate. The location contains two digits.

- **First digit:** determine the number (or letter) corresponding to the choices involving Quick Arm / Quick Bypass / UO Extender / Loudspeaker / Bell-Siren
- **Second digit:** determine the number (or letter) corresponding to the use of Silent Panic / Bell Squawk on Arming / 3 Minute Bypass

#### Comments on System Controls (Location 30: 1<sup>st</sup> Digit)

Quick Arm	Quick Bypass	UO Extender	Loudspeaker/Bell-Siren
Quick Arm eliminates the need for entering a User Code when arming to the STAY or AWAY modes. simply pressing <b>[STAY]</b> or <b>[ARM]</b> will arm the system to the respective mode	Eliminates the need to enter a User Code when bypassing a zone.	select <b>UO Extender</b> if the Utility Output Expansion Module is installed	select <b>Loudspeaker</b> if the external sounder(s) is NOT equipped with a built-in sound driver; doing so causes the ORBIT-6 to produce an oscillating frequency for the device, select <b>Bell/Siren</b> if the external sounder(s) is a bell or a buzzer or equipped with a built-in electronic sound driver;.

**Comments on System Controls (Location 30: 2<sup>nd</sup> Digit)**

Silent Panic	Bell Squawk on Arming	3 Minute Bypass Enabled
If "NO", the panic alarm will be AUDIBLE at the External Sounder and visual on the keypad. If "YES", the panic alarm will be INAUDIBLE at the External Sounder and invisible on the keypad.	If selected, <b>Bell Squawk on Arming</b> will produce a brief confirmation "chirp" from the system's external sounder(s) once the system is armed and the Exit Delay expires	If selected, <b>3-Minute Bypass Enabled</b> bypasses all zones automatically for 3 minutes when power is restored to an "unpowered" system—to prevent potential false alarms by allowing time for the stabilization of motion and/or smoke detectors

**Location: 30 System Controls: (1<sup>st</sup> Digit):**

1 <sup>st</sup> Digit	Loudspeaker/Bell-Siren	UO Extender	Quick Bypass	Quick Arm
0	Bell-Siren	No	No	No
1	Bell-Siren	No	No	Yes
2	Bell-Siren	No	Yes	No
3	Bell-Siren	No	Yes	Yes
4	Bell-Siren	Yes	No	No
5	Bell-Siren	Yes	No	Yes
6	Bell-Siren	Yes	Yes	No
7	Bell-Siren	Yes	Yes	Yes
8	Loudspeaker	No	No	No
9 (default)	Loudspeaker	No	No	Yes
A	Loudspeaker	No	Yes	No
B	Loudspeaker	No	Yes	Yes
C	Loudspeaker	Yes	No	No
D	Loudspeaker	Yes	No	Yes
E	Loudspeaker	Yes	Yes	No
F	Loudspeaker	Yes	Yes	Yes

**Location: 30 System Controls: (2<sup>nd</sup> Digit):**

2 <sup>nd</sup> Digit	3 Minute Bypass	CZ Installation	Bell Squawk on Arm	Silent Panic
0	Disabled	No	No	No
1	Disabled	No	No	Yes
2	Disabled	No	Yes	No
3	Disabled	No	Yes	Yes
**4	Disabled	Yes	No	No
**5	Disabled	Yes	No	Yes
**6	Disabled	Yes	Yes	No
**7	Disabled	Yes	Yes	Yes
8	Enabled	No	No	No
9	Enabled	No	No	Yes
A	Enabled	No	Yes	No
B (default)	Enabled	No	Yes	Yes
**C	Enabled	Yes	No	No
**D	Enabled	Yes	No	Yes
**E	Enabled	Yes	Yes	No
**F	Enabled	Yes	Yes	Yes

\*\* New in Ver. 1.3

System Controls:	
1 <sup>st</sup> Digit	

System Controls:	
2 <sup>nd</sup> Digit	

**PERIODIC TEST TIME: LOCATION 31**

If desired, the ORBIT-6 can send a daily test transmission to the Central Station to verify the operation of the unit's Digital Communicator.

<b>Location: 31</b>	<b>Periodic Test Time</b>	<b>Default: 0000</b>
---------------------	---------------------------	----------------------

Sets a fixed, daily time for sending an ORBIT-6 test transmission to the Central Station. The chosen time is expressed in 24-Hour format (following examples):

8:30 AM=0830      11:15AM=1115      4:30 PM=1630

If desired, disable the test transmission capability by accepting (or entering) the default (0000)

Periodic  
Test Time

--	--	--	--

**Note:** Failure to set the systems' time clock, will prevent the code from being sent to the Central Station.

**COMMUNICATOR REPORTING CODES: LOCATIONS 32 THROUGH 86**

To program the codes that will be transmitted by the ORBIT-6 to the Central Station. To prevent the corresponding event from being reported, use a "double-zero" (00, the default) in the location.

**Reporting Codes for Alarm Events:**

Location	Description	Digits	Default	Report Code
32	Zone 1 Alarm Reporting code	2	00	
33	Zone 2 Alarm Reporting code	2	00	
34	Zone 3 Alarm Reporting code	2	00	
35	Zone 4 Alarm Reporting code	2	00	
36	Zone 5 Alarm Reporting code	2	00	
37	Zone 6 Alarm Reporting code	2	00	
38	Zone 7 Alarm Reporting code	2	00	
39	Zone 8 Alarm Reporting code	2	00	
40	Keypad Fire Alarms Reporting code	2	00	
41	Keypad Panic Reporting code	2	00	
42	Keypad Special Emergency Reporting code	2	00	

**Notes on Alarm Restorals**

An ORBIT-6 Restoral Report informs the Central Station that the external sounder's operation, initially triggered by the respective alarm condition, has either "timed out" or been silenced by the act of system disarming. Be sure to check with Central Station personnel if restorals are permitted and, if so, what codes are required.

**Restoral Codes**

Location	Description	Digits	Default	Report Code
43	Zone 1 Restoral Code	2	00	
44	Zone 2 Restoral Code	2	00	
45	Zone 3 Restoral Code	2	00	
46	Zone 4 Restoral Code	2	00	
47	Zone 5 Restoral Code	2	00	
48	Zone 6 Restoral Code	2	00	
49	Zone 7 Restoral Code	2	00	
50	Zone 8 Restoral Code	2	00	
51	Keypad Fire Restoral Code	2	00	
52	Keypad panic Restoral Code	2	00	
53	Keypad Special Emergency Restoral Code	2	00	

## Other Reporting Codes

Location	Description	Digits	Default	Report Code
54	Daily test Report Code sent everyday at the time specified in Location 24	2	00	
55	User 0 arm (the "Master" Code, "Quick Arm" OR "Keyswitch" Arm)	2	00	
56	User 1 arm Reporting code	2	00	
57	User 2 arm Reporting code	2	00	
58	User 3 arm Reporting code	2	00	
59	User 4 arm Reporting code	2	00	
60	User 5 arm Reporting code			
61	User 6 arm Reporting code			
62	User 7 arm Reporting code			
63	User 8 arm Reporting code			
64	User 9 arm Reporting code			
65	Forced arm (when the system is armed with a bypassed zone) Reporting code	2	00	
66	Stay arm when the system is armed to the Stay (At Home) mode) Reporting code	2	00	
67	User 0, disarm Reporting code (key switch disarm)	2	00	
68	User 1 disarm Reporting code	2	00	
69	User 2 disarm Reporting code	2	00	
70	User 3 disarm Reporting code	2	00	
71	User 4 disarm Reporting code	2	00	
72	User 5 disarm Reporting code			
73	User 6 disarm Reporting code			
74	User 7 disarm Reporting code			
75	User 8 disarm Reporting code			
76	User 9 disarm Reporting code			
77	Duress Disarm			

## Trouble Reports and Restorals

Location	Description	Digits	Default	Report Code
78	Low Battery Reporting code	2	00	
79	loss of AC Power (for at least 15 min) Reporting code	2	00	
80	Fire zone trouble Reporting code	2	00	
81	Bell Loop Interrupted Reporting Code	2	00	
82	Low Battery restore Reporting code	2	00	
83	Loss of AC Power restore Reporting code	2	00	
84	Fire zone trouble Restore Reporting code	2	00	
85	Bell Loop Restored Reporting Code	2	00	
**86	Auto Arm	2	00	

\*\*New in Version 1.3



**CONTACT ID & SIA REPORT CODES FOR ORBIT 6**

<b>Event Reporting</b>	<b>Contact ID</b>		<b>SIA</b>	
<b>Zones Alarms/Disarm</b>	<b>Program Digit</b>	<b>Code</b>	<b>Program Digit</b>	<b>Code</b>
Exit/Entry Alarm	01	134	01	BA
Exit/Entry Restore	01	134	02	BH
Burglary Zone Alarm	03	130	03	BA
Burglary Zone Restore	03	130	04	BH
24 Hour Zone Alarm	05	133	05	BA
24 Hour Zone Restore	05	133	06	BH
Tamper Zone Alarm	07	137	07	TA
Tamper Zone Restore	07	137	08	TR
Smoke Zone Alarm/Restore	09	111		
Combustion Zone Alarm/Restore	1A	112		
Water Flow Zone Alarm/Restore	11	113	11	WA
Heat Zone Alarm	12	114	12	KA
Heat Zone Restore	12	114	13	KH
Duct Zone Alarm/Restore	14	116		
Flame Zone Alarm/Restore	15	117		
Panic Zone Alarm				
Restore				
Silent Alarm	16	122		
Audible Alarm	17	123		
Perimeter Zone Alarm/Restore	18	131	18	NL
Interior Zone Alarm/Restore	19	132		
Day/Night Zone Alarm/Restore	2A	135		
Outdoor Zone Alarm/Restore	21	136		
General Alarm/Restore	22	140		
Sensor Tamper Alarm/Restore	23	144		
24 Hour Non Burg Alarm/Restore	24	150		
Gas Detected Alarm	25	151	25	GA
Gas Detected Restore	25	151	26	GH
Refrigeration Zone Alarm/Restore	27	152		
Loss of Heat Alarm/Restore	28	153		
Water Leakage Alarm	29	154	29	WA
<b>Zones Alarms/Disarm</b>	<b>Program Digit</b>	<b>Code</b>	<b>Program Digit</b>	<b>Code</b>
Water Leakage Restore	29	154	3A	WH
Foil Break Alarm/Restore	31	155		
Low Battled Gas level Alarm/Restore	32	157		
High Temperature Alarm/Restore	33	158	33	DA

<b>Event Reporting</b>	<b>Contact ID</b>		<b>SIA</b>	
<b>Zones Alarms/Disarm</b>	<b>Program Digit</b>	<b>Code</b>	<b>Program Digit</b>	<b>Code</b>
Low Temperature Alarm/Restore	34	159	34	DA
Los of Air Flow	35	161	35	DB
<b>Special</b>				
Special Emergency Key Alarm	4A	100	4A	MA
Special Emergency Key Restore	4A	100	41	MH
Fire Zone Alarm	42	110	42	FA
Fire Zone Restore	42	110	43	FH
Fire Key Alarm	44	115	44	FA
Fire Key Restore	44	115	45	FH
Panic Key Alarm	46	120	46	PA
Panic Key Restore	46	120	47	PH
Duress Alarm	48	121	48	HA
Duress Restore	48	121	49	HH
<b>Troubles</b>				
AC Trouble	5A	301	5A	AT
AC Restore	5A	301	51	AR
Low Battery Trouble	52	302	52	YT
Low Battery Restore	52	302	53	YR
Main Bell Trouble	54	321	54	YA
Main Bell Restore	54	321	55	YH
Fire Trouble	56	373	56	FT
Fire Restore	56	373	57	FJ
<b>O/C Access</b>				
User Arm	6A	401	6A	CL
User Disarm	6A	401	61	OP
Quick Arm/Disarm - User 0	62	408		
Forced Arm	63	574	63	CF
Periodic Test	64	602	64	RP
Auto Alarm	65	403	65	CA

# ORBIT-6 Wiring Diagram

# FIGURE 1A

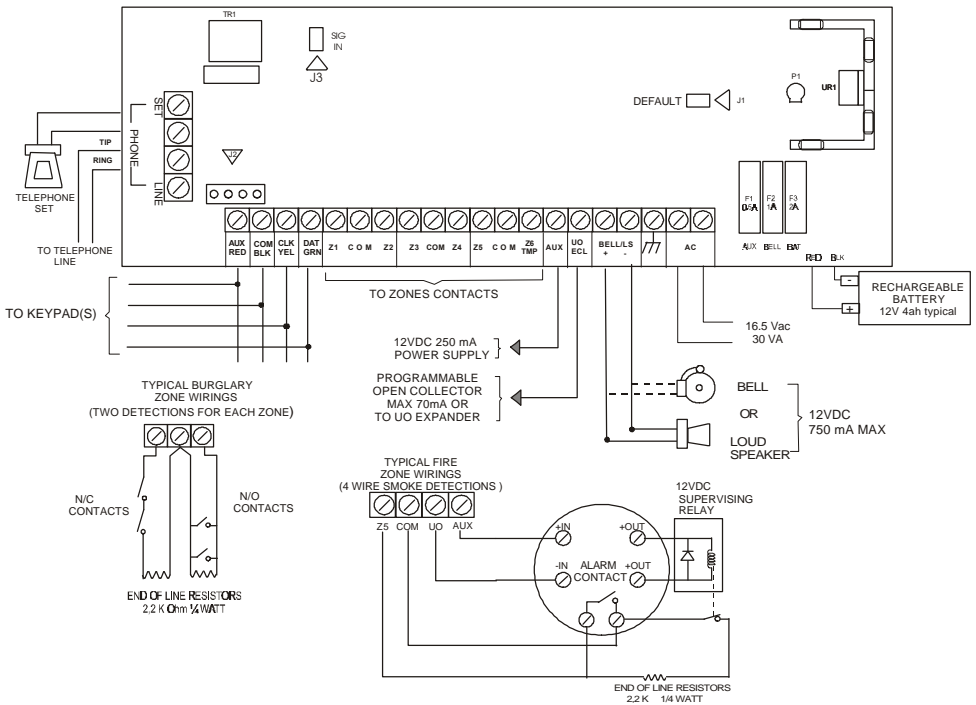

# ORBIT-6 Wiring Diagram

# FIGURE 1B

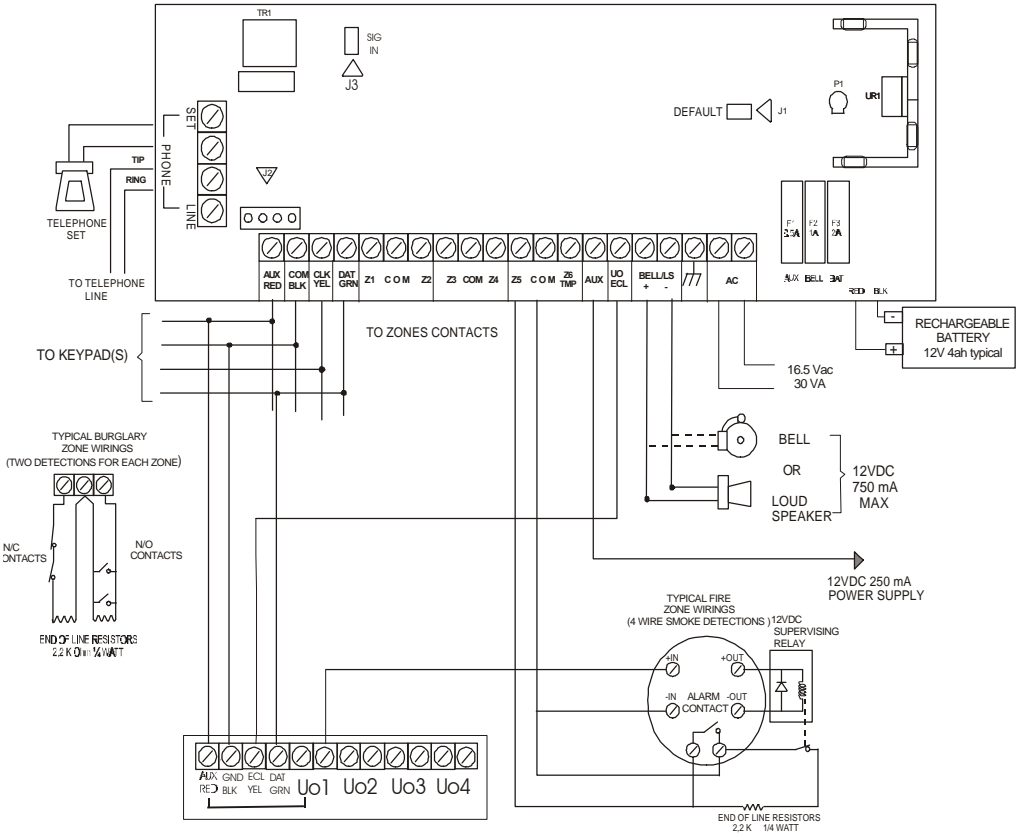

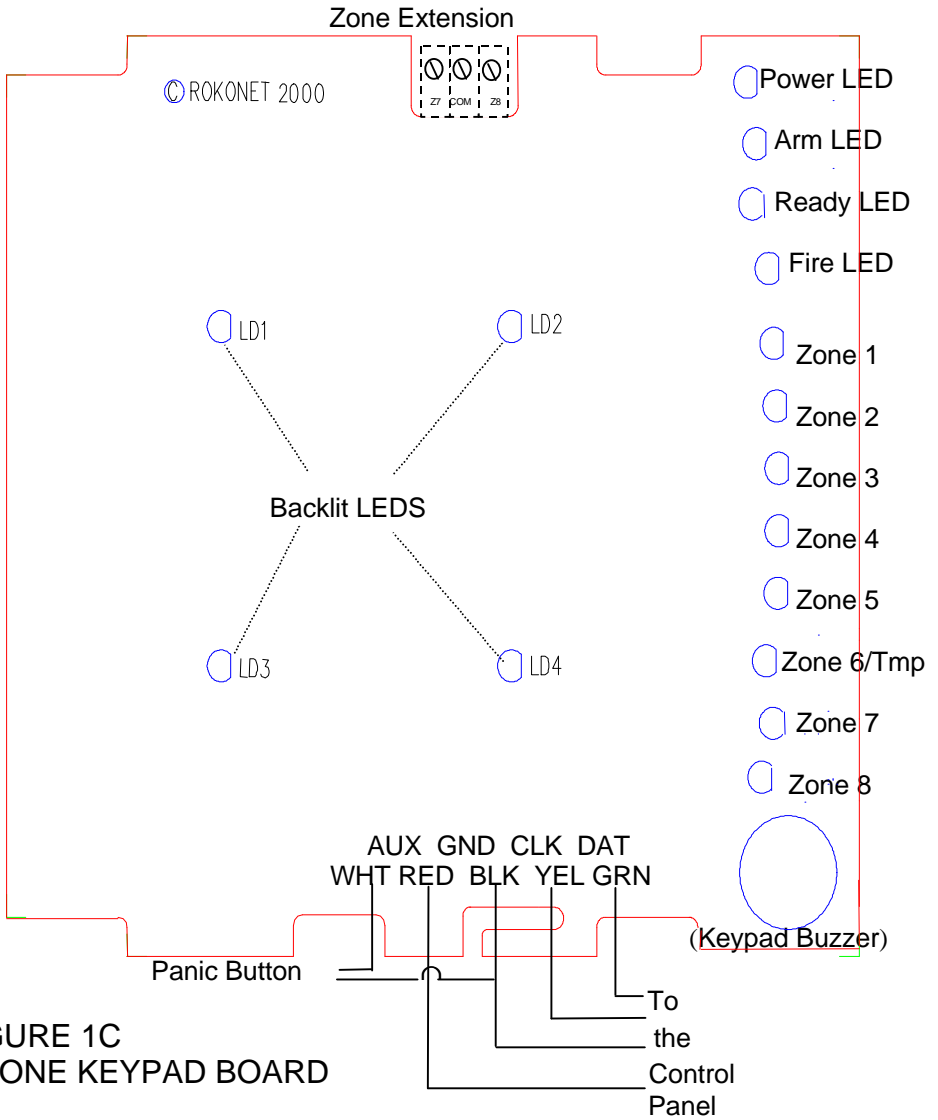

**FIGURE 1C**  
**8-ZONE KEYPAD BOARD**





## **ROKONET LIMITED WARRANTY**

Rokonet Electronics, Ltd. and its subsidiaries and affiliates ("Seller") warrants its products to be free from defects in materials and workmanship under normal use for 18 months from the date of production. Because Seller does not install or connect the product and because the product may be used in conjunction with products not manufactured by the Seller, Seller can not guarantee the performance of the security system which uses this product. Sellers obligation and liability under this warranty is expressly limited to repairing and replacing, at Sellers option, within a reasonable time after the date of delivery, any product not meeting the specifications. Seller makes no other warranty, expressed or implied, and makes no warranty of merchantability or of fitness for any particular purpose.

In no case shall seller be liable for any consequential or incidental damages for breach of this or any other warranty, expressed or implied, or upon any other basis of liability whatsoever.

Sellers obligation under this warranty shall not include any transportation charges or costs of installation or any liability for direct, indirect, or consequential damages or delay.

Seller does not represent that its product may not be compromised or circumvented; that the product will prevent any persona; injury or property loss by burglary, robbery, fire or otherwise; or that the product will in all cases provide adequate warning or protection. Buyer understands that a properly installed and maintained alarm may only reduce the risk of burglary, robbery or fire without warning, but is not insurance or a guaranty that such will not occur or that there will be no personal injury or property loss as a result.

Consequently seller shall have no liability for any personal injury, property damage or loss based on a claim that the product fails to give warning. However, if seller is held liable, whether directly or indirectly, for any loss or damage arising from under this limited warranty or otherwise, regardless of cause or origin, sellers maximum liability shall not exceed the purchase price of the product, which shall be complete and exclusive remedy against seller.

No employee or representative of Seller is authorized to change this warranty in any way or grant any other warranty.

**WARNING:** This product should be tested at least once a week.